



ZigBit 900 OEM Modules

MNZB-900-B0

REVISION 1.0

**Ultra-Compact 868MHz/915MHz
IEEE 802.15.4/ZigBee Modules
for Wireless Networking Applications**



Product Datasheet

Preliminary Version

Table of Contents

Summary	3
Applications	3
Key features	3
Benefits.....	3
Abbreviations and Acronyms.....	4
ZigBit 900 Module Overview.....	6
Specifications	7
Absolute Maximum Ratings**	8
Physical/Environmental Characteristics and Outline.....	9
Pin Configuration.....	10
Mounting Information.....	14
Soldering Profile	14
Antenna Reference Design.....	15
Related Documents	15
Ordering Information.....	16
Disclaimer.....	17
Trademarks	17
Technical Support	17
Contact Information.....	17

Summary

ZigBit 900 is an ultra-compact, extended range, low-powered, high-sensitivity 868MHz/915MHz IEEE 802.15.4/ZigBee OEM module from MeshNetics. ZigBit 900 modules eliminate the need for costly and time-consuming RF development, and shorten time to market for a wide range of wireless applications.

This module is the latest addition to the ZigBit family also represented by 2.4GHz modules ZDM-A1281-A2 (MNZB-24-A2), ZDM-A1281-B0 (MNZB-24-B0) [1], [2], and ZDM-A1281-PN/PN0 (MNZB-A24-UFL/U0) [3].

Applications

ZigBit 900 module ships with robust IEEE 802.15.4/ZigBee stack that supports a self-healing, self-organizing mesh network, while optimizing network traffic and minimizing power consumption. MeshNetics offers three stack configurations: BitCloud, SerialNet and OpenMAC. BitCloud is a certified, ZigBee PRO software development platform supporting reliable, scalable, and secure wireless applications running on MeshNetics ZigBit modules. SerialNet allows programming of the module via serial AT-command interface. OpenMAC is MeshNetics' open source implementation of IEEE 802.15.4 MAC layer intended for embedded software experts and enthusiasts.

The applications include, but are not limited to:

- Building automation & monitoring
 - Lighting controls
 - Wireless smoke and CO detectors
 - Structural integrity monitoring
- HVAC monitoring & control
- Inventory management
- Environmental monitoring
- Security
- Water metering
- Industrial monitoring
 - Machinery condition and performance monitoring
 - Monitoring of plant system parameters such as temperature, pressure, flow, tank level, humidity, vibration, etc.
- Automated meter reading (AMR)

Key features

- Ultra compact size (18.8 x 13.5 mm)
- High RX sensitivity (-110 dBm)
- Outperforming link budget (120 dB)
- Up to 11 dBm output power
- Very low power consumption (< 6 μ A in sleep mode)
- Ample memory resources (128K bytes of flash memory, 8K bytes RAM, 4K bytes EEPROM)
- Two modulation schemes (BPSK and O-QPSK)
- Wide range of interfaces (both analog and digital):
 - 9 spare GPIO, 2 spare IRQ lines
 - 4 ADC lines + 1 line for supply voltage control (up to 9 lines with JTAG disabled)
 - UART with CTS/RTS control
 - USART
 - I²C
 - SPI
 - 1-Wire
 - Up to 30 lines configurable as GPIO
- Capability to write own MAC address into the EEPROM
- IEEE 802.15.4 compliant
- 868 / 915 MHz band
- BitCloud embedded software, including UART bootloader and AT command set

Benefits

- Over 6 km (4 miles) outdoor line-of-sight range
- Extended battery life
- Small physical footprint and low profile for optimum fit in even the smallest of devices
- Mesh networking capability
- Easy-to-use low cost Development Kit
- Single source of support for HW and SW

Abbreviations and Acronyms

ADC	Analog-to-Digital Converter
API	Application Programming Interface
BPSK	Binary Phase-Shift Keying modulation scheme
DC	Direct Current
DTR	Data Terminal Ready
EEPROM	Electrically Erasable Programmable Read-Only Memory
ESD	Electrostatic Discharge
GPIO	General Purpose Input/Output
HVAC	Heating, Ventilating and Air Conditioning
HW	Hardware
I ² C	Inter-Integrated Circuit
IEEE	Institute of Electrical and Electronics Engineers
IRQ	Interrupt Request
ISM	Industrial, Scientific and Medical radio band
JTAG	Digital interface for debugging of embedded devices, also known as IEEE 1149.1 standard interface
MAC	Medium Access Control layer
MCU	Microcontroller Unit. In this document, it also means the processor, which is the core of ZigBit module
O-QPSK	Offset Quadrature Phase-Shift Keying modulation scheme
OEM	Original Equipment Manufacturer
OTA	Over-The-Air upgrade
PCB	Printed Circuit Board
PER	Packet Error Ratio
RAM	Random Access Memory
RF	Radio Frequency
RTS/CTS	Request to Send / Clear to Send
RX	Receive
SMA	Surface Mount Assembly
SPI	Serial Peripheral Interface bus
SW	Software
TTM	Time To Market
TX	Transmit

UART	Universal Asynchronous Receiver/Transmitter
USART	Universal Synchronous/Asynchronous Receiver/Transmitter
USB	Universal Serial Bus
ZDK	ZigBit Development Kit
ZigBee, ZigBee PRO	Wireless networking standards targeted at low-power sensor applications
802.15.4	The IEEE 802.15.4-2003 standard applicable to low-rate wireless Personal Area Networks

ZigBit 900 Module Overview

ZigBit 900 is an extended-range low-power, high-sensitivity IEEE 802.15.4/ZigBee-compliant OEM module, which occupies less than a square inch of space. Based on a solid combination of Atmel's latest AVR Z-Link hardware platform, power amplifier and low-noise amplifier, the ZigBit 900 offers an unmatched combination of superior radio performance, ultra-low power consumption and exceptional ease of integration.

ZigBit 900 contains Atmel's ATmega1281V Microcontroller [4] and AT86RF212 RF Transceiver [5]. The module features 128K bytes flash memory and 8K bytes RAM.

ZigBit 900 already contains a complete RF/MCU design with all the necessary passive components included. The module can be easily mounted on a simple 2-layer PCB with a minimum of required external connection. Compared to a single-chip solution, a module-based solution offers considerable savings in development time and NRE cost per unit during the design, prototyping, and mass production phases of product development.

To jumpstart evaluation and development, MeshNetics also offers a complete set of evaluation and development tools. The new ZigBit 900 Development Kit [7] comes with everything you need to create custom applications around ZigBit 900 module.

The kit features MeshBean development boards (MNZB-EVB-900-B0) with an easy-to-access extension connector for attaching third party sensors and other peripherals, and a JTAG connector for easy application uploading and debugging.

The kit also includes sample applications in C to speed up application development, open source hardware interface layer and reference drivers for the all the module interfaces, intuitive development environment from Atmel, and comprehensive set of application notes and product tutorials.

MNZB-900-B0 Block Diagram

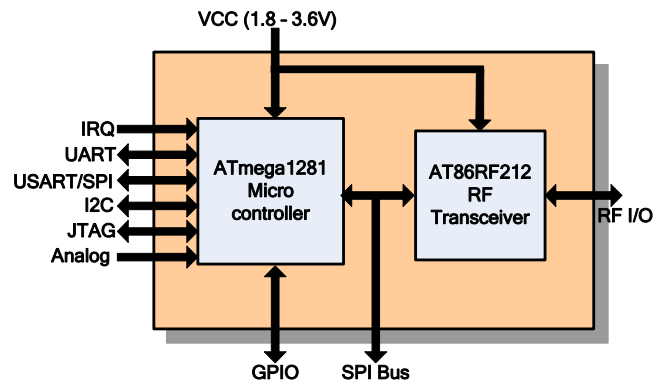

ZigBit 900 modules comes bundled with BitCloud, a 2nd generation embedded software stack from MeshNetics. BitCloud is fully compliant with ZigBee PRO and ZigBee standards for wireless sensing and control [8], [9], [10], and it provides an augmented set of APIs which, while maintaining 100% compliance with the standard, offer extended functionality designed with developer's convenience and ease-of-use in mind.

Depending on end-user design requirements, ZigBit 900 can operate as a self-contained sensor node, where it would function as a single MCU, or it can be paired with a host processor driving the module over a serial interface. In the former case, a user application may be used with the BitCloud software allowing customization of embedded applications through BitCloud's C API.

In the latter case, the host processor controls data transmission and manages module peripherals via an extensive set of SerialNet AT commands. Thus, no firmware customization is required for a successful module design-in. Additionally, third-party sensors can be connected directly to the module, thus expanding the existing set of peripheral interfaces. The over-the-air control via AT-commands eases network configuration and speeds up application prototyping. It also enables wireless module configuration during OEM mass-production process, providing a flexible commissioning protocol for installation and maintenance of ZigBit 900-based devices.

Specifications

Parameters	Range	Unit	Condition
Supply Voltage (V_{cc})	1.8 to 3.6	V	
Current Consumption: RX mode*	15	mA	
Current Consumption: TX mode*	20	mA	PTX=5 dBm
Current Consumption: Power Save mode*	<6	μ A	

Current consumption actually depends on multiple factors, including but not limited to, the board design and materials, BitCloud settings, network activity, EEPROM read/write operations. It also depends on MCU load and/or peripherals used by an application.

<i>RF Characteristics</i>			
Parameters	Range	Unit	Condition
Frequency Band	868 – 868.6, 902 – 928	MHz	
Number of Channels	11		
Channel Spacing	2	MHz	
Transmitter Output Power	-20 to +11	dBm	
Receiver Sensitivity*	-110	dBm	PER = 1%
On-Air Data Rate	20 (at 868 MHz), 40 (at 915 MHz) 100 (at 868 MHz), 250 (at 915 MHz)	kbps	BPSK modulation O-QPSK modulation
TX Output / Rx Input Nominal Impedance	100	Ohms	For balanced output
Range, outdoors*	6	km	With external 3 dBi antenna

* Preliminary data

<i>ATmega1281V Microcontroller Characteristics</i>			
Parameters	Value	Unit	Condition
On-Chip Flash Memory Size	128	Kbytes	
On-Chip RAM Size	8	Kbytes	
On-Chip EEPROM Size	4	Kbytes	
Operation Frequency	4	MHz	

<i>Module Interfaces Characteristics</i>			
Parameters	Value	Unit	Condition
UART Maximum Baud Rate	38.4	kbps	
ADC Resolution / Conversion Time	10 / 200	Bits / μ s	In the single conversion mode
ADC Input Resistance	> 1	MOhm	
ADC Reference Voltage (Vref)	1.0 to $V_{cc} - 0.3$	V	
ADC Input Voltage	0 to Vref	V	
I ² C Maximum Clock	222	kHz	
GPIO Output Voltage (High/Low)	2.3 / 0.5	V	(-10 / 5 mA, $V_{cc}=3V$)
Real Time Oscillator Frequency	32.768	kHz	

Absolute Maximum Ratings**

Parameter	Min Value	Max Value
Voltage of any Pin except RESET to Ground	- 0.5 V	$V_{cc} + 0.5$ V
DC Current per I/O Pin		40 mA
DC Current D_VCC and DGND Pins		300 mA
Input RF Level		+ 5 dBm

** **Absolute Maximum Ratings** are the values beyond which damage to the device may occur. Under no circumstances must the absolute maximum ratings given in this table be violated. Stresses beyond those listed under "Absolute Maximum Ratings" may cause permanent damage to the device.

This is a stress rating only. Functional operation of the device at these or other conditions, beyond those indicated in the operational sections of this specification, is not implied. Exposure to absolute maximum rating conditions for extended periods may affect device reliability.

Attention! ZigBit 900 is an ESD-sensitive device. Precaution should be taken when handling the device in order to prevent permanent damage.

Physical/Environmental Characteristics and Outline

Parameter	Value	Notes
Size, mm	18.8 x 13.5 x 2.0	
Operating Temperature Range, °C	- 20 to +70	- 40 to + 85 operational ¹
Operating Relative Humidity Range, %	no more than 80%	

MNZB-900-B0 Mechanical Drawing

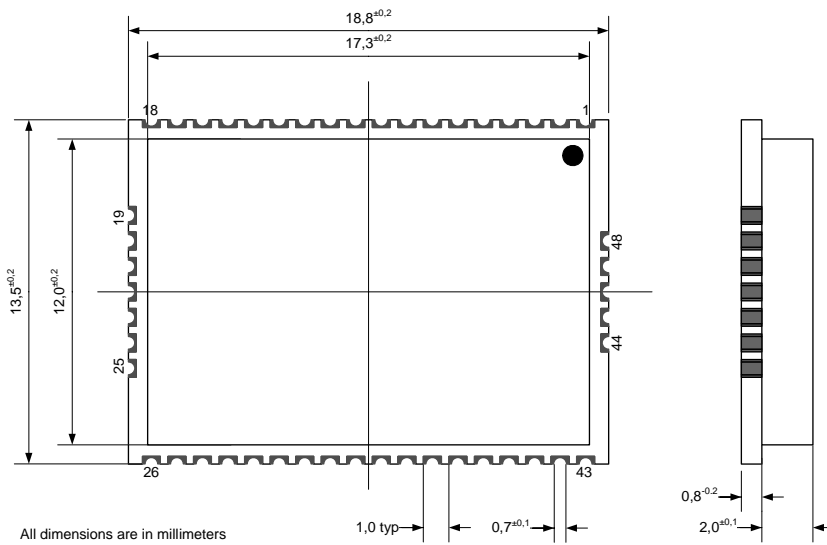

¹ Minor degradation of clock stability may occur

Pin Configuration

MNZB-900-B0 Pinout

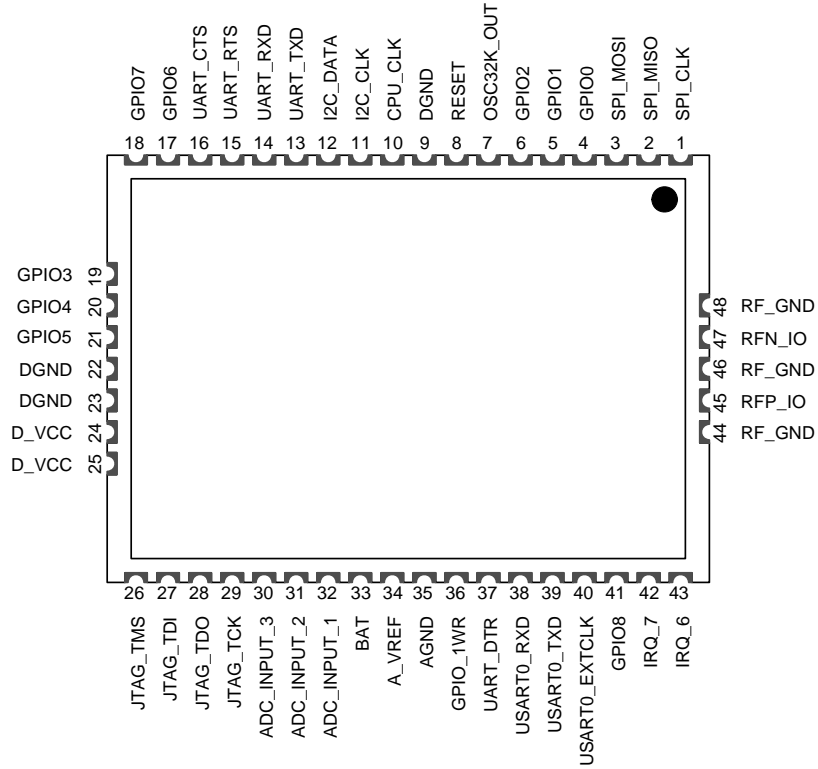

Pin Assignment

Connector Pin	Pin Name	Description	I/O	Default State after power on	Notes, see the list below
1	SPI_CLK	Reserved for stack operation	O		4
2	SPI_MISO	Reserved for stack operation	I/O		4
3	SPI_MOSI	Reserved for stack operation	I/O		4
4	GPIO0	General purpose digital input/output 0	I/O	tri-state	2, 3, 4, 7
5	GPIO1	General purpose digital input/output 1	I/O	tri-state	2, 3, 4, 7
6	GPIO2	General purpose digital input/output 2	I/O	tri-state	2, 3, 4, 7
7	OSC32K_OUT	32.768 kHz clock output.	O		4, 5
8	RESET	Reset input (active low).	I		4
9, 22, 23	DGND	Digital ground			
10	CPU_CLK	RF clock output. When module is in active state, 4 MHz signal is present on this line. While module is in the sleeping state, clock generation is stopped also.	O		4
11	I2C_CLK	I ² C serial clock output	O	tri-state	2, 3, 4, 7
12	I2C_DATA	I ² C serial data input/output	I/O	tri-state	2, 3, 4, 7
13	UART_TXD	UART receive input	I	tri-state	1, 2, 3, 4, 7

Connector Pin	Pin Name	Description	I/O	Default State after power on	Notes, see the list below
14	UART_RXD	UART transmit output	O	tri-state	1, 2, 3, 4, 7
15	UART_RTS	RTS input (Request To Send) for UART hardware flow control. Active low.	I	tri-state	2, 3, 4, 7
16	UART_CTS	CTS output (Clear To Send) for UART hardware flow control. Active low.	O	tri-state	2, 3, 4, 7, 8
17	GPIO6	General purpose digital input/output 6	I/O	tri-state	2, 3, 4, 7
18	GPIO7	General purpose digital input/output 7	I/O	tri-state	2, 3, 4, 7
19	GPIO3	General purpose digital input/output 3	I/O	tri-state	2, 3, 4, 7
20	GPIO4	General purpose digital input/output 4	I/O	tri-state	2, 3, 4, 7
21	GPIO5	General purpose digital input/output 5	I/O	tri-state	2, 3, 4, 7
24, 25	D_VCC	Digital supply voltage (V_{cc})			9
26	JTAG_TMS	JTAG test mode select	I		2, 3, 4, 6
27	JTAG_TDI	JTAG test data input	I		2, 3, 4, 6
28	JTAG_TDO	JTAG test data output	O		2, 3, 4, 6
29	JTAG_TCK	JTAG test clock	I		2, 3, 4, 6
30	ADC_INPUT_3	ADC input channel 3	I	tri-state	2, 3, 7
31	ADC_INPUT_2	ADC input channel 2	I	tri-state	2, 3, 7
32	ADC_INPUT_1	ADC input channel 1	I	tri-state	2, 3, 7
33	BAT	ADC input channel 0. Used for battery level measurement. This pin level equals to $V_{CC} / 3$.	I	tri-state	2, 3, 7
34	A_VREF	Output/Input reference voltage for ADC	I/O	tri-state	
35	AGND	Analog ground			
36	GPIO_1WR	1-Wire Interface	I/O		2, 3, 4, 7
37	UART_DTR	DTR input (Data Terminal Ready) for UART. Active low.	I	tri-state	2, 3, 4, 7
38	USART0_RXD	UART/SPI receive pin	I	tri-state	2, 3, 4, 7
39	USART0_TXD	UART/SPI transmit pin	O	tri-state	2, 3, 4, 7
40	USART0_EXTCLK	UART/SPI external clock	I	tri-state	2, 3, 4, 7
41	GPIO8	General purpose digital input/output 8	I/O	tri-state	2, 3, 4, 7
42	IRQ_7	Digital input interrupt request 7	I	tri-state	2, 3, 4, 7
43	IRQ_6	Digital input interrupt request 6	I	tri-state	2, 3, 4, 7
44, 46, 48	RF_GND	RF analog ground			
45	RFP_IO	Differential RF input/output.	I/O		
47	RFN_IO	Differential RF input/output.	I/O		

Notes:

1. The UART_TXD pin is intended for input (i.e. its designation as "TXD" implies some complex system containing ZigBit 900 as its RF terminal unit), while UART_RXD pin, vice versa, is for output.
2. Most of pins can be configured for general purpose I/O or for some alternate functions as described in details in the ATmega1281V Datasheet [4].

3. GPIO pins can be programmed either for output, or for input with/without pull-up resistors. Output pin drivers are strong enough to drive LED displays directly (refer to figures on pages 387-388, [4]).
4. All digital pins are provided with protection diodes to D_VCC and DGND.
5. It is strongly recommended to avoid assigning an alternate function for OSC32K_OUT pin because it can be used by BitCloud. However, this signal can be used in rare cases if other peripheral or host processor requires 32.768 kHz clock, otherwise this pin should be disconnected.
6. Normally, JTAG_TMS, JTAG_TDI, JTAG_TDO, JTAG_TCK pins are used for on-chip debugging and flash burning. They can be used for A/D conversion if JTAGEN fuse is disabled.
7. The following pins can be configured with the BitCloud software to be general-purpose I/O lines: GPIO0, GPIO1, GPIO2, GPIO3, GPIO4, GPIO5, GPIO6, GPIO7, GPIO8, GPIO_1WR, I2C_CLK, I2C_DATA, UART_TXD, UART_RXD, UART_RTS, UART_CTS, ADC_INPUT_3, ADC_INPUT_2, ADC_INPUT_1, BAT, UART_DTR, USART0_RXD, USART0_TXD, USART0_EXTCLK, IRQ_7, IRQ_6. Additionally, four JTAG lines can be programmed as GPIO as well, but this requires changing the fuse bits. Then, JTAG debugging would be disabled.
8. With BitCloud, CTS pin can be configured to indicate sleep/active condition of the module thus providing mechanism for power management of host processor. If this function is necessary, connection of this pin to external pull-down resistor is recommended to prevent the undesirable transients during module reset process.
9. Using ferrite bead and 1 μ F capacitor located closely to the power supply pin is recommended, as shown in *Typical Application Schematics* below.

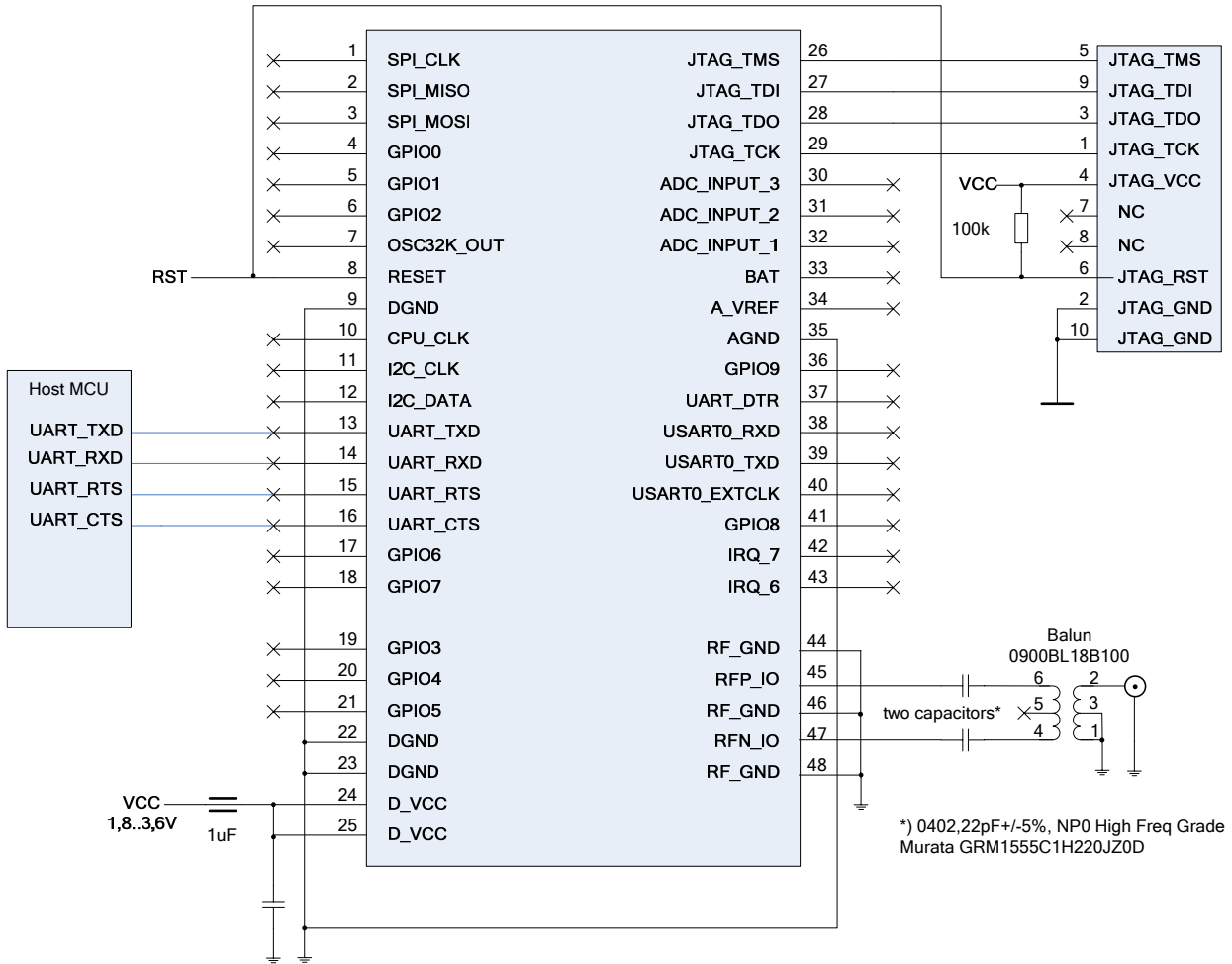

Mounting Information

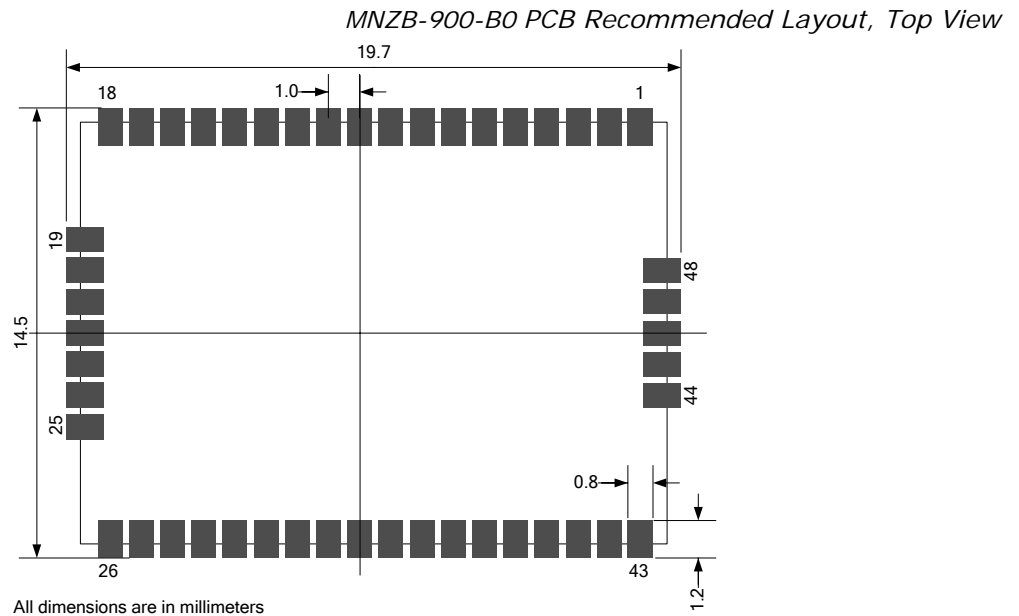

The above diagrams show the PCB layout recommended for ZigBit 900 module. Neither via-holes nor wires are allowed on the PCB upper layer in area occupied by the module. As a critical requirement, RF_GND pins should be grounded via several holes to be located right next to pins thus minimizing inductance and preventing both mismatch and losses.

Soldering Profile

The J-STD-020C-compliant soldering profile is recommended, as given below.

Soldering Profile

Profile Feature	Green Package
Average ramp-up rate (217 °C to peak)	3 °C/s max.
Preheat temperature 175 °C ± 25 °C	180 s max.
Temperature maintained above 217 °C	60 s to 150 s
Time within 5 °C of actual peak temperature	20 s to 40 s
Peak temperature range	260 °C
Ramp-down rate	6 °C/s max.
Time 25 °C to peak temperature	8 minutes max.

Note: The package is backward compatible with Pb/Sn soldering profile.

Antenna Reference Design

Multiple factors affect proper antenna match, hence, affecting the antenna pattern. The particular factors are the board material and thickness, shields, the material used for enclosure, the board neighborhood, and other components adjacent to antenna.

General Recommendations:

- Metal enclosure should not be used. Using low profile enclosure might also affect antenna tuning.
- Placing high profile components next to antenna should be avoided.
- Having holes punched around the periphery of the board eliminates parasitic radiation from the board edges also distorting antenna pattern.
- ZigBit 900 module should not be placed next to consumer electronics which might interfere with ZigBit 900's RF frequency band.

The board design should prevent propagation of microwave field inside the board material. Electromagnetic waves of high frequency may penetrate the board thus making the edges of the board radiate, which may distort the antenna pattern. To eliminate this effect, metalized and grounded holes must be placed around the board's edges.

Related Documents

- [1] ZigBit™ OEM Modules. Product Datasheet. MeshNetics Doc. M-251~01
- [2] ZigBit™ Development Kit User's Guide. MeshNetics Doc. S-ZDK-451~01
- [3] ZigBit™ Amp OEM Modules. Product Datasheet. MeshNetics Doc. M-251~03
- [4] Atmel 8-bit AVR Microcontroller with 64K/128K/256K Bytes In-System Programmable Flash. 2549F-AVR-04/06
- [5] Atmel AT86RF212 Low Power 800/900 MHz Transceiver for IEEE 802.15.4b, Zigbee, and ISM Applications. Preliminary specification. Rev. 2007-11-27.
- [6] Ultra Small Surface Mount Coaxial Connectors - Low Profile 1.9mm or 2.4mm Mated Height. http://www.hirose.co.jp/cataloge_hp/e32119372.pdf
- [7] ZigBit 900 Development Kit. User's Guide. MeshNetics Doc. S-ZDK-451~03
- [8] IEEE Std 802.15.4-2003 IEEE Standard for Information technology – Part 15.4 Wireless Medium Access Control (MAC) and Physical Layer (PHY) Specifications for Low-Rate Wireless Personal Area Networks (LR-WPANs)
- [9] ZigBee Specification. ZigBee Document 053474r17, October 19, 2007
- [10] BitCloud™ IEEE802.15.4/ZigBee Software. Product Datasheet. MeshNetics Doc. M-252~08

Ordering Information

Contact MeshNetics for ordering ZigBit 900 modules and/or ZigBit 900 Development Kit.

Please specify the product part number and description when ordering ZigBit 900 modules:

Part Number	Description
MNZB-900-B0	868/915 MHz IEEE802.15.4/ZigBee OEM Module with Balanced RF Port

The ZigBit 900 Development Kit is offered with **2 support packages**:

- **ZigBit 900 Development Kit Lite** offers access to standard evaluation and development tools and comes with 45 days of complimentary support. This option is good for product demonstration, platform evaluation and quick application prototyping.
- **ZigBit 900 Development Kit Complete** comes with 1 year of professional support which provides users with continuous software updates, dedicated design-in support, and RF design assistance. It's ideal for customers engaged in a full cycle of developing, prototyping, and launching innovative products made possible by MeshNetics ZigBit wireless platform. It also features early software release access, and additional sample applications, including sources for WSN Demo application, examples of API use, and more.

ZSDK Edition	Lite	Complete
Part Number	MNZB-DKL-900	MNZB-DKC-900
Support Duration	45 days	1 year
Hardware design support	+	+
RF design support	+	+
Software development support	+	+
Early software release access ²	-	+
Access to Gerber Files ³	-	+
Access to bootloader source code ⁴	-	+
Additional sample applications ⁵	-	+
Response time	72 h, workdays	72 h, workdays
Support channel	E-mail	E-mail

² Early software release access covers technology previews and demos, preliminary datasheets, and advance product announcements.

³ MeshBean Gerber files greatly expedite custom PCB design-in and accelerate TTM for customer's specific products based on ZigBit modules and peripherals used within MeshBean development platform such as USB extension, sensor adaptations and others.

⁴ Access to serial bootloader source code is essential in building custom tools for serial and OTA upgrades.

⁵ Additional sample applications include sources for (1) the embedded portion of WSN Demo, featuring the most comprehensive example of a typical data acquisition scenario, (2) smaller examples of API use, which may be used as application "building blocks", (3) sample applications featuring integration of ZigBit w/ 3-rd party sensors.

Disclaimer

MeshNetics believes that all information is correct and accurate at the time of issue. MeshNetics reserves the right to make changes to this product without prior notice. Please visit MeshNetics website for the latest available version.

MeshNetics does not assume any responsibility for the use of the described product or convey any license under its patent rights.

MeshNetics warrants performance of its hardware products to the specifications applicable at the time of sale in accordance with MeshNetics standard warranty. Testing and other quality control techniques are used to the extent MeshNetics deems necessary to support this warranty. Except where mandated by government requirements, testing of all parameters of each product is not necessarily performed.

Trademarks

MeshNetics®, ZigBit, BitCloud, SensiLink, LuxLabs, Luxoft Labs, and MeshNetics, Luxoft Labs and ZigBit logos are trademarks of LuxLabs Ltd, dba MeshNetics.

All other product names, trade names, trademarks, logos or service names are the property of their respective owners.

Technical Support

Technical support is provided by MeshNetics.

E-mail: support@meshnetics.com

Please refer to Support Terms and Conditions for full details.

Contact Information

MeshNetics

EMEA Office
Am Brauhaus 12
01099, Dresden, Germany
Tel: +49 351 8134 228
Office hours: 8:00am - 5:00pm (Central European Time)
Fax: +49 351 8134 200

US Office
5110 N. 44th St., Suite L200
Phoenix, AZ 85018 USA
Tel: (602) 343-8244
Office hours: 9:00am - 6:00pm (Mountain Standard Time)
Fax: (602) 343-8245

Russia Office
9 Dmitrovskoye Shosse, Moscow 127434, Russia
Tel: +7 (495) 725 8125
Office hours: 8:00am - 5:00pm (Central European Time)
Fax: +7 (495) 725 8116

E-mail: info@meshnetics.com

www.meshnetics.com

© 2008 MeshNetics. All rights reserved.

No part of the contents of this manual may be transmitted or reproduced in any form or by any means without the written permission of MeshNetics.