

owasys Advanced Wireless Devices

*Time to
wireless*

owasys



LOCATED IN THE TECHNOLOGY
PARK OF ZAMUDIO, A KEY
RESEARCH AND DEVELOPMENT
CENTRE IN EUROPE, OWASYS IS A
COMPANY SPECIALIZING IN
DESIGN, DEVELOPMENT,
MANUFACTURING AND
INTERNATIONAL SALES OF
ADVANCED WIRELESS DEVICES.

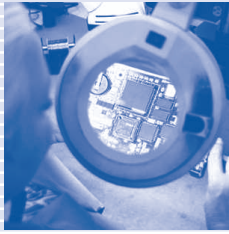

A team with unique know-how and experience in:



Development and launching of Wireless devices

We have a professional team, who in the last 15 years has led the complete development and launching of such products as:

- Wireless communication modules, with GSM 900/1800/1900, GPS and Bluetooth™.
- GSM Mobile Telephones. Robust and water resistant.
- Mobile Telephones: NMT 450, ETACS, GSM.
- Fixed Cellular Terminals (GSM/NMT/DAMPS/ETACS) for wireless in local loop systems.

Owasys is a member of the Bluetooth™ SIG, Car Working Group. Due to its expertise and previous work, owasys is one of the main drivers, of Bluetooth™ Handsfree standard profile as well as other specifications under development within the group.



Wireless market and technologies

M2M COMMUNICATIONS (MACHINE- TO- MACHINE)

We have an in-depth knowledge of machine-to-machine communication dynamics, rules and needs in this state-of-the-art technology.

ELECTRONIC PRODUCT DESIGN

We use the most innovative wireless technology, for the design of highly reliable electronic products with advanced features.

HIGH VOLUME MANUFACTURING

We have the methodology and know-how of the design, development, certification, industrialisation, and logistics for high volume manufacturing of wireless terminals.

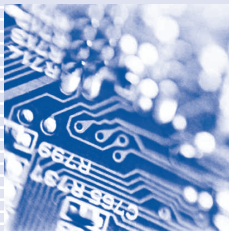

Advanced technologies for creating new devices

We create innovative wireless terminals that enable the adoption of traditional Wireless telephony in vertical markets and user groups.

BASED ON:

- 2.5G and 3 G cellular telephony.
- GPS and Galileo.
- Bluetooth and WLAN.
- Mobile Internet.
- Miniaturization

WE MAKE TERMINALS FOR:

- Positioning and Alarm Transmission.
- Remote Monitoring and Control.
- Cable replacing.
- Adapted personal telephony and telematics.

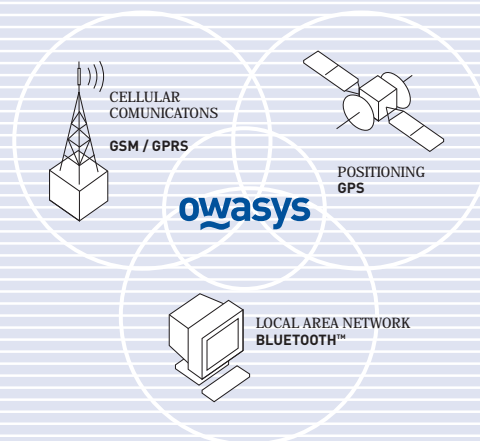



A solution to every need

OWASYS CUSTOMERS ARE:

- System Integrators
- Providers at First Level (TIER 1)
- Telephony Operators and
- Consumer Groups.

For them we have a family of devices to cover needs in a variety of market areas:



Automotive

Your reference partner for on board wireless communication nodes!

OEM and Aftermarket Devices oriented to:

- Fleet Management
- AVL - Automatic Vehicle Location
- On Board Telematic Unit



Industrial

Now remote devices at your fingertips!

Devices for wireless networks in industrial environments:

- Security and Alarms
- Utilities
- Elevators
- Industrial Machinery



Consumers

Making daily life more accessible!

Owasys has developed a platform that allows the launching of wireless telephones and other adapted devices, for use by those with specific needs:

- Telecare
- Telemedicine
- Adapted Telephony



Add competitive advantages to your products

REDUCE COSTS

We assure optimum designs and sufficient economies of scale for our customers to be able to concentrate on their core business and reduce costs in the development of their products.

HAVE LEADING EDGE TECHNOLOGIES

- Because we have an expertise that gives us a unique know-how.
- Because we are a present force in today's international telecommunication fora.
- Because we establish strategic alliances with key market players.

OPTIMISE THE USE OF EXISTING WIRELESS NETWORKS

We create innovative devices that allow increased use of the network through the introduction of new applications and services.

ENSURE THE SUCCESS OF YOUR OBJECTIVES

We adapt ourselves to the specific requirements of every customer and technology, with flexibility and resources to guarantee the highest quality.

owa2X Family

WIRELESS EMBEDDED COMPUTERS FOR REMOTE MANAGEMENT

owa2X family of “Wireless Embedded Computers” provides an open, flexible and powerful platform offering fully wireless solutions for management of geographically distributed machinery.

owa2X units integrate GSM/GPRS communications with embedded IP functionality, allowing an efficient transmission of information across the cellular wireless network.

Local wired interfaces, such as Ethernet, analog and digital I/Os or serial and audio ports, and wireless interfaces like Bluetooth™ or WLAN, enable the different products of the platform to interface with a variety of accessories and perform wired and wireless networking. GPS is also available within the family.

Smart integration of state-of-the-art technologies and components, together with the embedded Linux OS, pave the way to easily build a wide range of powerful, highly reliable and cost efficient customer applications.

owa2X family provides the hardware that enables the rapid deployment of applications such as:

- Fleet Management.
- AVL-Automotive Vehicle Location.
- On board Telematic units.
- Security & Alarms.
- Energy Management, Utilities.
- Vending Machines.
- Elevators.
- Industrial Machinery.
- Telemetry and remote Supervision
- Optimized Logistics
- Extended Warehouse
- Banking ...

*Let us make the Hardware for Wireless Applications
If you, as system integrator, use wireless technologies
for your customer applications, just focus on adding
value to your business and leave “us” the rest.
Owasys, your partner for wireless!*

owasys

Advanced Wireless Devices

**FULL COMPATIBILITY WITH YOUR APPLICATION
AT ANY STAGE OF YOUR DEVELOPMENT.**

owa2X PLATFORM

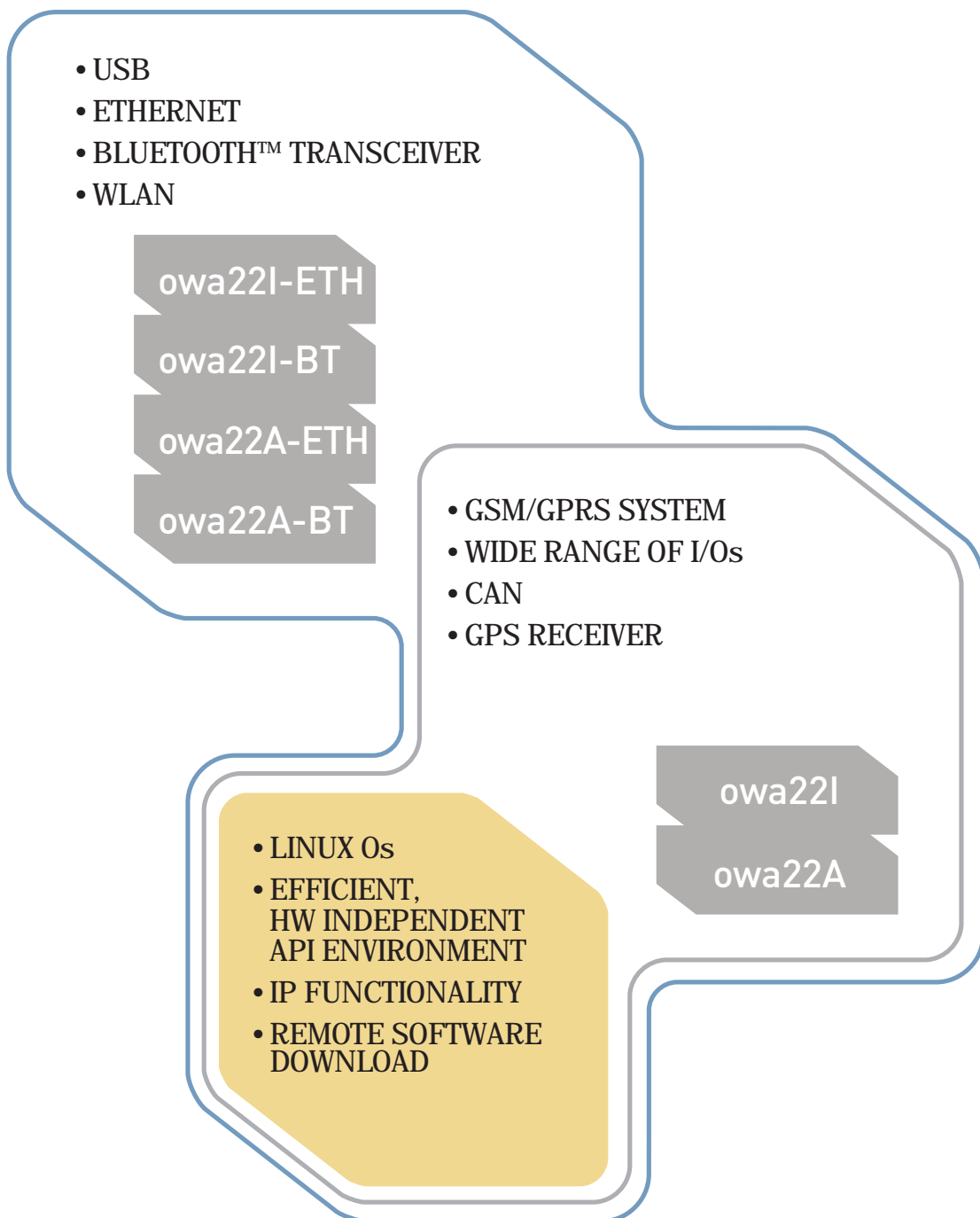

FEATURES AND BENEFITS



LINUX OS

Due to its high reliability and robustness, Linux is the selected OS to avoid any failure in a management or monitoring platform which is ON 24/7. In addition, as an open standard, many freeware applications and tools are available.

EFFICIENT, HW INDEPENDENT API ENVIRONMENT

Developers are now able to build powerful applications thanks to the memory and processing capabilities available in the Owa2X platform.

In order to manage the platform resources, a complete library of APIs for GSM/GPRS functions, Internet connection, management of the interfaces, GPS management and other services is offered. Thus, the developer does not have to worry about low level hardware and protocols, but only focus on the application by means of user-friendly APIs that reduce development times and increase the reliability of the application itself.

IP FUNCTIONALITY

Owa2X works as an independent, autonomous IP node. Any device connected to the platform can display its status and information, so that it is accessible, any time, anywhere in the world via the Internet. Direct access to Internet significantly reduces costs and enhances efficiency, enabling a wide range of new wireless applications.

REMOTE APPLICATION SOFTWARE DOWNLOAD

Owa2X enables remote upgrading of customer software applications over the air via GSM/GPRS network. This feature gives the opportunity of updating the application even when the device is already installed and running in the field.

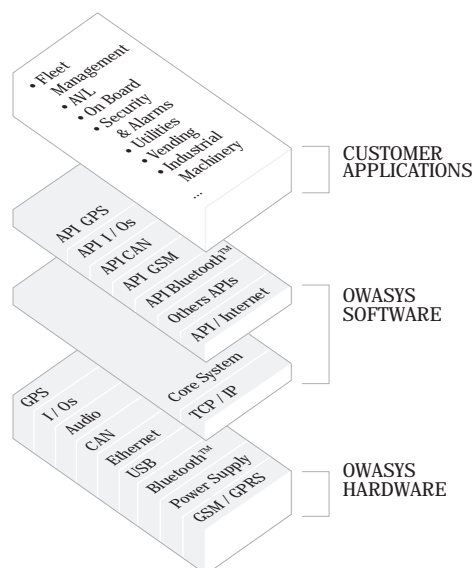

GSM/GPRS SYSTEM

General Packet Radio Service (GPRS) is a widely deployed value added service of the cellular infrastructure that enables direct access to public and private data networks (Internet, corporate networks, private networks...). GPRS involves overlaying a packet based air interface on the existing Circuit Switched GSM network, enabling resources to be allocated only when data is to be sent/received. Thus, data network usage is completely efficient and traffic costs are significantly reduced.

WIDE RANGE OF I/Os

By offering audio, serial ports (RS-232, RS-485) and a set of generic analog and digital I/Os, the Owa2X platform allows a wide range of peripherals and sensors to be connected and monitored.

CAN (CONTROLLER AREA NETWORK STANDARD)

Owa2X platform includes a standard CAN Bus interface that allows communication with distributed devices. The CAN standard allows low cost connectivity in environments such as automation, agriculture, maritime, construction, medical, factory automation, home automation...

GPS RECEIVER

The GPS receiver provides accurate positioning and time information necessary for Location Based Applications, such as Fleet Management or Wireless Emergency Services. GPS is a satellite based positioning system with world wide coverage.



USB

USB (Universal Serial Bus) is a wired high speed interface, currently available in many computers, and intended for connecting a host with multiple peripherals like printers, disk drives, cameras and many other application specific devices or dongles.

ETHERNET

Ethernet is the most widely used standard for wired networking between computers. It is based on the IEEE 802.x family of standards.

BLUETOOTH™ TRANSCIVER

Bluetooth™ is a short range wireless communications standard, operating in the 2, 4 Ghz, license free ISM band. The Bluetooth™ transceiver enables wireless connection to standard peripherals, like printers, PDA's, laptops, or headsets, and it is ideal for short range wireless supervision and data capture applications.

WLAN

WLAN is an adaptation of the Ethernet standard for short range wireless networking. Owasys implementation is based on the IEEE 802.11 standard, operating in the 2, 4 GHz, license free ISM band.

THE BASELINE RANGE

PRODUCT	EXAMPLE OF APPLICATIONS	MAIN FEATURES
owa22I	<ul style="list-style-type: none"> • Long range Telemetry and Remote supervision in Industrial applications. 	<ul style="list-style-type: none"> • Linux OS. • GSM/GPRS. • Embedded IP Functionality. • Remote application upgrade. • RS485, CAN, IOs.
owa22A	<ul style="list-style-type: none"> • Fleet Management. • Automotive Telematics. • Automotive Vehicle Location 	<ul style="list-style-type: none"> • Linux OS • GSM/GPRS. • Embedded IP Functionality. • Remote application upgrade. • RS485, CAN, IOs. • GPS.

THE FEATURED RANGE.

Over the same platform, new products with additional features, providing more flexibility to access to a wider range of Applications.

PRODUCT	EXAMPLE OF APPLICATIONS	MAIN FEATURES
owa22I-ETH	<ul style="list-style-type: none"> • Wireless long range Telemetry and Remote supervision in Industrial environments using Ethernet enabled devices. 	<ul style="list-style-type: none"> • USB 1.1 host connectivity. • Ethernet 10baseT (10 Mbps, RJ45). • Embedded IP routing and firewall capabilities.
owa22I-BT	<ul style="list-style-type: none"> • Wireless long and short range Telemetry and Supervision (data and voice) in Industrial applications. 	<ul style="list-style-type: none"> • USB 1.1 host connectivity. • 100 meters Bluetooth™ connectivity. • Bluetooth™ serial ports emulation. • Bluetooth™ voice applications. • Embedded IP routing and firewall capabilities.
owa22A-ETH	<ul style="list-style-type: none"> • Wireless onboard telematics gateway in Automotive environment. 	<ul style="list-style-type: none"> • USB 1.1 host connectivity. • Ethernet 10baseT (10 Mbps, RJ45). • Embedded IP routing and firewall capabilities.
owa22A-BT	<ul style="list-style-type: none"> • Wireless onboard telematics gateway in Automotive environment 	<ul style="list-style-type: none"> • USB 1.1 host connectivity. • 100 meters Bluetooth™ connectivity. • Bluetooth™ serial ports emulation. • Bluetooth™ voice applications. • Embedded IP routing and firewall capabilities.

OPTIONS

- Battery Back- Up.
- WLAN (only for "ETH" versions, via external WLAN dongle).

OWASYS
 Parque Tecnológico, 207-B
 E-48170 Zamudio. Vizcaya (Spain)
 Tel: +34 946 025 323
 Fax: +34 946 025 353
 e-mail: info@owasys.com

www.owasys.com

owa22A

owa2X family

WIRELESS TELEMATIC UNIT

HARDWARE TERMINAL WITH OPEN SOFTWARE FOR THE DEVELOPMENT OF WIRELESS AUTOMOTIVE APPLICATIONS.
WIRELESS DEVICE THAT MAKES VEHICLE POSITIONING AND COMMUNICATIONS POSSIBLE.
LOCATE AND TALK TO YOUR FLEET, TURNING KILOMETRES INTO MILLIMETERS.
NO MATTER HOW FAR YOUR VEHICLE IS, YOUR DRIVER AND CARGO ARE ACCOMPANIED BY YOU.
COMBINES LINUX OS, GSM/GPRS WITH IP CONNECTIVITY AND GPS.

- GPRS Class B, Class 8 (4+1), GSM dual band 900/1800.
- ARM 7 core up to 60 MIPS, Linux OS and 1 Mbyte FLASH Memory free for customer application.
- GPS integrated.
- TCP/IP stack for transparent Internet Connection.
- Interfaces: RS232, RS485, CAN, Audio, general purpose analog and digital I/Os.
- Small Size.
- Application software upgradeable over the air.

Your reference partner for on board wireless telematic nodes!



168 mm. (W)

35 mm. (H)

55,25 mm. (L)

owasys

Advanced Wireless Devices

TECHNICAL SPECIFICATIONS

GENERAL SPECIFICATIONS

- Power Supply:
 - Nominal Voltage Range: 12 to 36 Vdc.
 - Maximum Voltage Range: 8 to 40 Vdc.
- Interfaces:
 - Power Supply.
 - 2 Analog Inputs.
 - 7 Digital Inputs (4 + 3).
 - 5 Digital Outputs (4 + 1), 2 configurable as PWM.
 - Audio IN/OUT (2,5 W).
 - RS-232 Serial Port.
 - RS-485 Port.
 - CAN Port.
 - Odometer Input.
 - GSM antenna connector.
 - GPS antenna connector.
- Approvals
 - CE Marking.
 - e-marking.
- Power Consumption-Typical Average @24V

Off	0,2 mA
Deep Sleep(1)	13 mA
Run(2)	115 mA
Battery Recharge(3)	55 mA

- (1) Only CPU in stand by.
 (2) CPU+GSM (voice call at max. Power)+GPS, running.
 (3) Only for owa22A/b

- Temperature:

Operating	-25°C to +55°C
Operating but not fully compliant with GSM	-25°C to +70°C
Storage	-40°C to +85°C
Operation with battery back up (3)	-20°C to +55°C

- (3) Only for owa22A/b

FIRMWARE SPECIFICATIONS

- 32 bits RISC ARM7 core up to 60 MIPS (Dhrystone 2.1) at 70 Mhz.
- Linux OS (Kernel v.2.4.18).
- Memory:
 - 4 Mbyte FLASH (1 Mbyte available for SW application)
 - 16 Mbyte RAM (2 Mbyte available for SW application)
- Application Programming Interface for:
 - Owa22A control.
 - Power management.
 - GSM/GPRS.
 - Internet connection.
 - Controlling all the interfaces: I/Os, CAN.
 - GPS.

OWASYS

Parque Tecnológico, 207-B
 E-48170 Zamudio, Vizcaya (Spain)
 Tel: +34 946 025 323
 Fax: +34 946 025 353
 e-mail: info@owasys.com

www.owasys.com

GSM/GPRS SPECIFICATIONS

- EGSM 900 / GSM1800.
- Power Output at 900 MHz: 2W.
- Power Output at 1800 MHz: 1W.
- GPRS Class B, Class 8 (4+1).
- Audio calls.
- Data calls.
- SMS (MT/MO).

GPS SPECIFICATIONS

- Receiver: L1 frequency, 12 Channels.
- Update Rate: ≥ 1 Hz.
- Accuracy: 4m CEP (Circular Error Probability).
- Signal Acquisition:
 - Cold Start: 45 sec.
 - Warm Start: 38 sec.
 - Hot Start: < 8 sec.
- Signal Reacquisition: 100 ms.
- 3,3 Volt power supply for active antenna.

MECHANICAL SPECIFICATIONS

- Dimension: 168 (W) x 35 (H) x 55,25 (L).
- Weight: 290 gr.
- Material: Aluminium anodized.
- Connectors:
 - 2 SMA (female).
 - Molex 24 pins P/N 90130-3124.
 - RJ45.
 - 2 Jack 3,5 mm.
 - RS-232 DB-9 (female).
 - Molex Mini-fit 6 pins P/N 39-30-1060.
 - SIM card holder.

DEVELOPMENT KIT

A development kit is available, including:

- GSM/GPRS antenna.
- GPS antenna.
- Developer's board.
- Power supply cable.
- Cables for interfaces.
- CD with: Cross compiler, API's library, manuals, and applications notes.

RELATED PRODUCTS

- Owa22A/b: with battery back-up.
- Owa22I: without GPS.
- Universal Development Kit: a kit designed to accelerate the owa2X products integration and develop powerful applications.
- owa22I/22A-BT: 100 meters Bluetooth™ connectivity and USB 1.1.
- owa22I-ETH: Ethernet 10baseT (10 Mbps, RJ45) and USB 1.1.

owa22I

owa2X family

INTELLIGENT DATA CAPTURE GSM/GPRS TERMINAL

GSM/GPRS HARDWARE TERMINAL WITH OPEN SOFTWARE FOR THE DEVELOPMENT OF WIRELESS APPLICATIONS IN INDUSTRIAL ENVIRONMENTS. INTELLIGENT DATA CAPTURE TERMINAL.

HIGHEST RELIABILITY IN DATA TRANSMISSION AND REMOTE CONTROL. RATIONALIZING RESOURCES AND PROVIDING THE BEST SOLUTION FOR EVERY CASE.

COMBINES LINUX OS, GSM/GPRS WITH IP CONNECTIVITY.

- GPRS Class B, Class 8 (4+1), GSM dual band 900/1800.
- ARM 7 core up to 60 MIPS, Linux OS and 1 Mbyte FLASH Memory free for customer application.
- TCP/IP stack for transparent Internet Connection.
- Interfaces: RS232, RS485, CAN, Audio, general purpose analog and digital I/Os.
- Small Size.
- Application software upgradeable over the air.

Now, remote devices at the control of your fingertips!



168 mm. (W)

35 mm. (H)

55,25 mm. (L)

owasys

Advanced Wireless Devices

TECHNICAL SPECIFICATIONS

GENERAL SPECIFICATIONS

- Power Supply:
 - Nominal Voltage Range: 12 to 36 Vdc.
 - Maximum Voltage Range: 8 to 40 Vdc.
- Interfaces:
 - Power Supply.
 - 2 Analog Inputs.
 - 7 Digital Inputs (4 + 3).
 - 5 Digital Outputs (4 + 1), 2 configurable as PWM.
 - Audio IN/OUT (2,5 W).
 - RS-232 Serial Port.
 - RS-485 Port.
 - Odometer Input
 - CAN Port.
 - GSM antenna connector.
- Approvals
 - CE Marking.
 - e-marking

Power Consumption-Typical Average @24V

Off	0,2 mA
Deep Sleep(1)	13 mA
Run(2)	90 mA
Battery Recharge(3)	55mA

(1) Only CPU in stand by.

(2)CPU+GSM (voice call at max. Power), running.

(3)Only for owa22I/b.

Temperature:

Operating	-25°C to +55°C
Operating but not fully compliant with GSM	-25°C to +70°C
Storage	-40°C to +85°C
Operation with battery back up (3)	-20°C to +55°C

(3)Only for owa22I/b

FIRMWARE SPECIFICATIONS

- 32 bits RISC ARM7 core up to 60 MIPS (Dhrystone 2.1) at 70 Mhz.
- Linux OS (Kernel v.2.4.18).
- Memory:
 - 4 Mbyte FLASH (1 Mbyte available for SW application)
 - 16 Mbyte RAM (2 Mbyte available for SW application)
- Application Programming Interface for:
 - Owa22I control.
 - Power management.
 - GSM/GPRS.
 - Internet connection.
 - Controlling all the interfaces: I/Os, CAN.

GSM/GPRS SPECIFICATIONS

- EGSM 900 / GSM1800.
- Power Output at 900 MHz: 2W.
- Power Output at 1800 MHz: 1W.
- GPRS Class B, Class 8 (4+1).
- Audio calls.
- Data calls.
- SMS (MT/MO).

MECHANICAL SPECIFICATIONS

- Dimension: 168 (W) x 35 (H) x 55,25 (L).
- Weight: 280 grams
- Material: Aluminium Anodized.
- Connectors:
 - 1 SMA (female).
 - Molex 24 pins P/N 90130-3124.
 - RJ45.
 - 2 Jack 3,5 mm.
 - RS-232 DB-9 (female).
 - Molex Mini-fit 6 pins P/N 39-30-1060.
 - SIM card holder.

DEVELOPMENT KIT

A development kit is available, including:

- GSM/GPRS antenna.
- Developer's board.
- Power supply cable.
- Cables for interfaces.
- CD with: Cross compiler, API's library, manuals, and application notes.

RELATED PRODUCTS

- Owa22I/b: with battery back-up.
- Owa22A: with GPS.
- Universal Development Kit: a kit designed to accelerate the owa2X products integration and develop powerful vertical applications.
- owa22I/22A-BT: 100 meters Bluetooth™ connectivity and USB 1.1.
- owa22I-ETH: Ethernet 10baseT (10 Mbps, RJ45) and USB 1.1.

OWASYS

Parque Tecnológico, 207-B
E-48170 Zamudio. Vizcaya (Spain)
Tel: +34 946 025 323
Fax: +34 946 025 353
e-mail: info@owasys.com

Universal Development Kit

UDK owa2X Family

A KIT DESIGNED TO ACCELERATE THE owa2X PRODUCTS INTEGRATION AND DEVELOP POWERFUL VERTICAL APPLICATIONS.

THE CORE COMPONENT OF THE UDK IS THE CD, INCLUDING THE CROSS COMPILER AND FULL API DOCUMENTATION AND MANUALS.

BESIDES THAT, A PROGRAMMING GUIDE INCLUDING CODE EXAMPLES AND A RICH SET OF APPLICATION NOTES IS PROVIDED TO DEVELOP POWERFUL VERTICAL APPLICATIONS.

INTEGRATION IN THE REAL ENVIRONMENT CAN BE EASILY EMULATED BY CONNECTING THE CABLES, ANTENNAS AND DEVELOPER'S BOARD INCLUDED IN THE UDK.

THIS DEVELOPMENT KIT CONTAINS THE FOLLOWING ITEMS:

• CD CONTENTS:

- Cross compiler.
- owa2X Family Programming Guide.
- owa2X Family Integrators Manual.
- owa2X Family Programming Reference Manual.
- owa2X Family Developers Board Manual.
- Application Examples.
- owa2X Family Datasheet.

• ACCESSORIES:

- Power Supply Cable.
- AC/DC Power Supply.
- RS-232 Null Modem Serial Cable.
- Multipurpose Connector Cable.
- RJ45 Cable.
- Ethernet Cable.
- Bluetooth™ Antenna.
- GSM Antenna.
- GPS Antenna.
- Headset (with microphone and earphone).
- owa2X Family Developer's Board.



NOTE: AS THIS IS A UNIVERSAL DK, COMMON TO ALL PRODUCTS IN owa2X Family, CHECK ORDERING INFO TO GET THE owa2X UNIT THAT FITS TO YOUR APPLICATION.

owasys Advanced Wireless Devices

OWASYS
Parque Tecnológico, 207-B
E-48170 Zamudio, Vizcaya (Spain)
Tel: +34 946 025 323
Fax: +34 946 025 353
e-mail: info@owasys.com

www.owasys.com