



μWEB Lite GSM/ GPRS
GPRS & GSM DUAL BAND
INTELLIGENT MODEM MODULE
AUDIO and GPS COMPATIBLE

DESIGN MANUAL

FEATURES

- GPRS Class B Module 4+1
- HSCSD, 2 Downlink, 1 Uplink
- 3/5V Serial TTL or RS232 Level Interface
- Built in SIM socket
- SMS support
- FAX support
- Configurable power down modes
- Configurable wake events
- Programmable SMS send events
- Sleep power consumption TBA
- SMS IO control and monitoring
- Dual band for use with all GSM networks using both 900MHz and 1800MHz (950 / 1900MHz version available).
- Auto Answer on Ring Detect
- Small mechanical outline
59mm x 89mm (approx)
- Extended AT & AT+ command set
- -20°C to 55°C (75°C) operating Temperature Range
- Onboard TCP/IP Stack
 - Email
 - FTP Client
 - Sockets

The μWEB Lite GSM/GPRS is one of a new family of intelligent GSM and GPRS communications modules. Optional support is available for audio and GPS.

Using the very latest GSM/GPRS technology together with onboard intelligence, very low power modes, suitable for long-term battery use, are standard. This together with configurable wake event and auto send of SMS makes the μWEB Lite GSM/GPRS idea for applications where communications is required but is not supported by the host equipment.

This product was specifically designed for use in embedded modem applications where space, performance, power consumption, ease of use and fast time to market are key requirements.

Filename	UWEBL_DM.DOC	Document Revision	1.7
Date of Issue	29 March 2007	Page Number	Page 1 of 71

µWEB Lite GSM/GPRS EMBEDDED INTELLIGENT MODEM

The µWEB Lite GSM/GPRS family of modems have been designed to meet the requirements of the R&TTE Directive for pan-European connection to the GSM network.

As such this modem should work on GSM networks in the following EC member countries:

Austria	Belgium	Cyprus	Czech Republic	Denmark
Estonia	Finland	France	Germany	Greece
Holland	Hungary	Ireland	Italy	Latvia
Lithuania	Luxembourg	Malta	Poland	Portugal
Slovakia	Slovenia	Spain	Sweden	UK

All other product names are copyright and registered trademarks/trade names of the respective owners.

Comtech Holdings reserves the right to alter the specification of the products described in this manual at any time and without prior notice.

This document is copyrighted and may not, in whole or part, be copied, photocopied, reproduced, translated or reduced to any electronic or machine readable form without prior consent in writing from Comtech Holdings Ltd.

All rights reserved © 2005 Comtech Holdings Ltd

Printed in England

Any queries regarding information in this manual, please contact Comtech Holdings (Comtech) Ltd at the address on the front page. Information provided in this document is believed correct at time of printing but is subject to change without notice. Comtech will not accept liability for any loss, damage or costs howsoever caused as a result of the information provided.

Filename	UWEBL_DM.DOC	Document Revision	1.7
Date of Issue	29 March 2007	Page Number	Page 2 of 71

Contents

1	Introduction.....	6
2	Host Design Guidelines.....	6
2.1	Mounting The PCB	6
2.2	Power Supply.....	7
2.3	Data Levels.....	7
2.3.1	TTL Data Levels (applicable to TTL version only).....	7
2.3.2	RS-232 Data Levels (applicable to RS232 version only).....	8
2.4	SIM.....	8
3	Connector Information.....	10
3.1	Connector Layout	10
3.2	Pin Headers	10
3.3	Aux Power In Connector.....	10
3.4	Antenna Connector.....	11
3.5	Antenna.....	11
3.5.1	Antenna Type.....	11
3.5.2	Antenna Placement.....	11
3.5.3	Antenna Cable	11
3.6	SIM Connector.....	11
4	Header Descriptions.....	12
4.1	Power and Host Serial Header –CON1 (& CON7)	12
4.1.1	/RESET	12
4.1.2	DGND	13
4.2	AUX Power In – CON6	13
4.3	Audio Header – CON5.....	14
4.3.1	Audio To Mobile Station – ATMS.....	14
4.3.2	Audio From Mobile Station - AFMS	15
4.4	Microphone Signals	16
4.4.1	Speaker Signals.....	16
4.5	I/O Header – CON2	17
4.6	Interface Header – CON3.....	17
4.6.1	GPS interface (checked against µWEB Lite schematics).....	18
4.7	Network Status & RTC – CON4.....	18
4.8	GSM/GPRS Antenna Connector	19
5	Comtech MMCX to SMA Cables.....	20
5.1	Cable-004	20
5.2	Cable-018	20
6	GSM Characteristics	21
6.1	µWEB Lite GSM/GPRS EUR (for Europe)	21
6.2	µWEB Lite GSM/GPRS FCC (for USA).....	21
7	Functional Description.....	22
7.1	Firmware	22
7.1.1	SMTP Client (Email)	22
7.1.2	FTP Client (File Transfer)	22
7.1.3	Automated.....	22
8	Host Interface	29
8.1	Extended AT# Commands.....	29
8.2	Automated.....	31
8.2.1	AT#MO Automated mode of operation.....	31

Filename	UWEBL_DM.DOC	Document Revision	1.7
Date of Issue	29 March 2007	Page Number	Page 3 of 71

8.2.2 AT#WAK Wakeup Source 32

8.2.3 AT#AL Alarm Control..... 33

8.2.4 AT#CMN Call matching number 34

8.2.5 AT#PWD SMS Password 35

8.2.6 AT#USR SMS Username 35

8.2.7 AT#THL Lower ADC threshold 36

8.2.8 AT#THU Upper ADC threshold..... 36

8.2.9 AT#TE End timer period 37

8.2.10 AT#TS Start timer 37

8.3 SMTP client..... 38

8.3.1 AT#SUS SMTP Authentication Username 38

8.3.2 AT#SPA SMTP Authentication Password 38

8.3.3 AT#HOST SMTP Hostname 38

8.3.4 AT#ATT File Attachment name 38

8.3.5 AT#EML Send Email..... 39

8.4 FTP client..... 40

8.4.1 AT#FUS FTP Server Username 40

8.4.2 AT#FPA FTP Server Password 40

8.4.3 AT#FPF FTP Put File Name..... 40

8.4.4 AT#FGF FTP Get File Name 40

8.4.5 AT#FPF FTP Put File..... 41

8.4.6 AT#FGF FTP Get File..... 42

8.4.7 AT#FMF FTP File Move..... 43

8.4.8 AT#FPS FTP Put Stream 44

8.4.9 AT#FGS FTP Get Stream..... 45

8.4.10 AT#FMS FTP Move Stream 46

8.5 TCP socket client..... 47

8.5.1 AT#PUS PPP Username 47

8.5.2 AT#PPA PPP Password..... 47

8.5.3 AT#RIP Remote IP address 48

8.5.4 AT#RPO Remote Port number 48

8.5.5 AT#TCP Establish a TCP connection..... 48

8.6 Filing System 49

8.6.1 AT#RD Read File..... 49

8.6.2 AT#WR Write Data to File 49

8.6.3 AT#WRLN Write Data to File and Append 49

8.6.4 AT#DEL Delete File 50

8.6.5 AT#DIR List Files..... 50

8.7 I/O and ADC monitoring..... 51

8.7.1 AT#IOC IO Direction Control 51

8.7.2 AT#IOW IO Port Write 52

8.7.3 AT#IOR IO Port Read..... 52

8.7.4 AT#IOA IO Port AND 53

8.7.5 AT#IOO IO Port OR..... 53

8.7.6 AT#ADR Read ADC channel..... 54

8.8 GPS 55

8.8.1 AT#GPC GPS Unit Control..... 55

8.8.2 AT#GPL GPS location (GPRMC string) 55

8.8.3 AT#GPT GPS timeout..... 55

8.9 Configuration..... 56

8.9.1 AT#CFG Configuration Bitmap Register..... 56

8.9.2 AT#BR Baudrate Control..... 57

8.9.3 AT#D Autodial number..... 57

8.9.4 AT#F Restore default factory configuration 58

8.9.5 AT#G Control GR47/48 ENGINE..... 58

8.9.6 AT#INI Initialisation String 58

8.9.7 AT#MRI Modem Reset Interval 59

8.9.8 AT#MRST Modem Reset..... 59

8.9.9 AT#PAU Pause..... 59

8.9.10 AT#RSC RS232 Mode..... 59

Filename	UWEBL_DM.DOC	Document Revision	1.7
Date of Issue	29 March 2007	Page Number	Page 4 of 71

8.9.11 AT#RTC Real Time Clock Control..... 60

8.9.12 AT#SLP Sleep Mode Enable..... 61

8.9.13 AT#SMS Static SMS Message..... 61

8.9.14 AT#STO Store Configuration..... 61

8.9.15 AT#Z Reset device..... 61

8.10 Information..... 62

8.10.1 AT#HELP List available AT# commands..... 62

8.10.2 AT#I Module identity..... 62

8.10.3 AT#V Firmware Version number..... 62

9 Remote Command Line Access..... 63

10 Updating Firmware..... 64

10.1 Local Firmware Update..... 64

10.2 Remote Firmware Update..... 64

11 ELECTRICAL CHARACTERISTICS..... 65

11.1 DC Electrical Characteristics..... 65

11.2 Current Consumption..... 66

11.3 Timing Characteristics..... 66

12 MECHANICAL SPECIFICATIONS..... 67

12.1 Plan View..... 67

12.2 SMA Connector View..... 67

13 APPROVALS IN EUROPE..... 68

13.1 Integration with μWeb Lite for Europe..... 68

13.2 Integration with μWeb Lite for USA..... 68

13.3 Documentation required..... 68

13.4 Power supply..... 68

13.5 EMC & Safety Testing..... 68

13.6 RF Testing..... 69

13.6.1 900/1800MHz variant for Europe (GR47)..... 69

13.6.2 850/1900MHz variant for USA (GR48)..... 69

13.7 SAR warning..... 69

14 PRODUCT ORDER CODES..... 70

14.1 Accessories..... 70

15 Document History..... 71

Table of Figures

Figure 1: μWEB LITE GSM/GPRS Connector Layout..... 10

Figure 2: Microphone connections to module..... 16

Filename	UWEBL_DM.DOC	Document Revision	1.7
Date of Issue	29 March 2007	Page Number	Page 5 of 71

1 Introduction

The μWEB Lite GSM/GPRS is a family of GSM and GPRS intelligent modem modules for internally embedded modem use such as in machine-to-machine applications.

Supported features are:

- Extended AT Command Set
- TTL or RS232 Compatible Serial Host Interface
- Internal SIM card socket for 3V or 5V SIM's.
- GR47: 900/1800MHz
- GR48: 850/1900MHz (*variant product – please contact Comtech Holding for further information*)
- Data Support
 - GPRS (general packet radio service, Class B 4+1)
 - CSD, (circuit switched data at 9600 baud)
 - HSCSD (high speed circuit switch data one slot uplink, two slots downlink per frame 2+1)
- SMS to GSM 03.40.
- SMS status reports to GSM 03.40
- SMS modes supported MO, (mobile originated), MT (mobile terminated) & CBM (cell broadcasts message)
- Class 1 FAX.
- Audio Support, using optional Audio/GPS Module.
 - HR (half rate),
 - FR (full rate)
 - EFR (enhance full rate)
- GPS Support, support for NMEA 0183 protocol using external GPS Module (contact marketing)
- Configurable power down, standby and sleep modes.
- Configurable wake events and actions.

2 Host Design Guidelines

2.1 Mounting The PCB

Care must be taken when designing the host equipment and mounting the μWEB LITE GSM/GPRS to ensure that Regulatory Safety Approvals are NOT INVALIDATED.

Ensure that minimum CREEPAGE and CLEARANCE DISTANCES for HOST or other expansion modules and μWEB LITE GSM/GPRS are maintained. Refer to the STATUTORY REQUIREMENTS section of this manual.

Ensure that the μWEB LITE GSM/GPRS antenna socket is accessible with the HOST enclosure fitted and ensure that the antenna ground is NOT connected to the supply ground as this may result in damage to the unit. Antennas, which are through panel/chassis mounting and have a electrical connection to the panel/chassis should not be used. Suitable antennas are available from Comtech.

Filename	UWEBL_DM.DOC	Document Revision	1.7
Date of Issue	29 March 2007	Page Number	Page 6 of 71

2.2 Power Supply

The Vcc input supplies the module with external power which shall be supplied by a limited power source (LPS). Any other voltages needed are generated internally.

The power supply requirements for the µWeb Lite modems are listed below.

Parameter	Limit	Condition
Minimum Input Voltage	4.75V	DC only
Maximum Input Voltage	15V	DC only
Supply current capacity	0.6A	Average at full transmit power
	<1.5A	Peak current at full TX power
Maximum voltage drop	0.2V	During transmit burst
Ripple and noise on Vcc supply	<0.1V	Peak to peak for <200kHz
	<20mV	Peak to peak for >200KHz

Notes

1. Whilst the uWeb Lite has significant internal capacitance to handle most of the large current peaks during GSM transmission it is still very important that the external VCC power supply is capable of meeting the high current peaks and that the supply impedance is minimised as failure to do so can result in these surges causing brown-out events internal to the modem which will invoke a reset. It is therefore important that the user ensures that the above criteria are met when integrating the module and that the external power supply chosen is not pushed into current limit by worst-case peak current demands during transmission.
2. Supply of power using the 10 way IDC ribbon header is not recommended for ribbon cable length great than 10cm. For longer cable runs the aux power connector (CON6) must be used, and suitable cable with low resistance selected. This should ensure that the voltages at the connector pins are within the allowed range even during maximum peak current demand.
3. Given the low current standby modes of the µWeb Lite modem, care should be taken to ensure the regulations and stability of the power supply used.

2.3 Data Levels

The µWEB LITE GSM/GPRS can be specified to accept either TTL or RS-232 voltage levels for the data signals.

Care should be taken to ensure you use the correct levels for your particular board.

2.3.1 TTL Data Levels *(applicable to TTL version only)*

The input lines TXD, RXD, DTR, DCD, CTS, RTS, RI to the board can handle both 3v and 5v signals.

Parameter	Conditions	Min	Max
HIGH Level Input Voltage Vih	--	2.0V	5.5V

Filename	UWEBL_DM.DOC	Document Revision	1.7
Date of Issue	29 March 2007	Page Number	Page 7 of 71

LOW Level Input Voltage Vil	--	-	0.8V
HIGH Level Output Voltage Voh	-10mA	2.7V	-
LOW Level Output Voltage Vol	10mA	-	0.4V

Note! *It is recommended that 3v signals are used to interface to this modem, to achieve the low currents in sleep modes.*

2.3.2 RS-232 Data Levels (applicable to RS232 version only)

The transmit output are 5.0V EIA/TIA-232 levels. Data rates are guaranteed to 250kbps with worst-case loads of 3kΩ in parallel with 1000pF.

The RS232 driver, in order to achieve low power operation, will auto shutdown approx 30 seconds after the last state change on any of the RS232 port signals.

In this shutdown state the output levels of the RS232 port will be at 0 volts. Any state change on the RS232 port, or from the network, which generates a transition or data, such as incoming ring, SMS etc will wake the RS232 driver from sleep .

For connection to a standard 9 way serial port an adaptor is available from Comtech or refer to http://www.comtech.uk.com/downloads/Network_Adapters/UWEB_LITE_GSM/GPRSE/Application_Notes/Rs232cab.pdf.

If auto shut down is not required contact Comtech for available options.

Receiver Inputs

Parameter	Min	Typ	Max	Units
Input Voltage range	-25		25	Volts
Input Threshold Low	0.6	1.2		Volts
Input Threshold Low (RTS only)		2.5		Volts
Input Threshold High		1.5	2.4	Volts
Input Threshold High (RTS only)		3		Volts

Transmitter Outputs

Parameter	Min	Typ	Max	Units
Output Voltage Swing	±5.0	±5.4		Volts
Output Resistance	300	10M		Ω
Output short-circuit current		±35	±60	mA
Output Leakage Current			±25	μA

All RS-232 inputs and outputs have enhanced ESD protection to ±15kV.

2.4 SIM

The SIM contains all of the information required to allow the unit to connect to the subscribers network. It is also used to store telephone numbers and SMS messages.

Filename	UWEBL_DM.DOC	Document Revision	1.7
Date of Issue	29 March 2007	Page Number	Page 8 of 71

SIM's are usually NOT supplied data enabled. It is often possible to send data with a non-data enabled SIM but it is not possible to receive an incoming data call. A separate data number is often issued if the SIM is voice and data enabled.

This SIM interface allows the use of 3V and 5V SIM cards. By default it works on 3V levels but will automatically switch to 5V, if a 5V SIM card is fitted.

Note! ***Check with your service provider to ensure that your SIM is enabled for the features you require (voice, data, GPRS etc)***

Filename	UWEBL_DM.DOC	Document Revision	1.7
Date of Issue	29 March 2007	Page Number	Page 9 of 71

3 Connector Information

3.1 Connector Layout

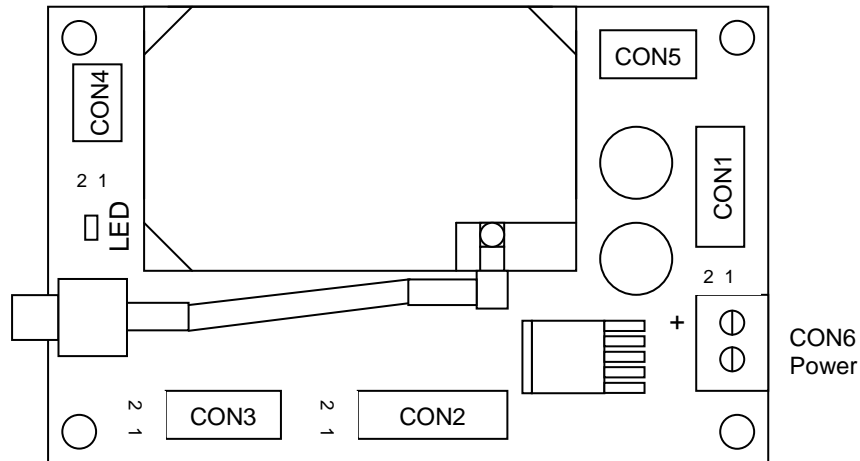

Figure 1: μWEB LITE GSM/GPRS Connector Layout

Connector	Description
CON1	Power and Host Serial Header (top side of PCB)
CON2	I/O Header
CON3	Interface Header (GPS serial header)
CON4	Network Status and Real Time Clock (RTC)
CON5	Audio Header
CON6	Aux Power In
CON7	Power and Host Serial Header (bottom side of PCB (if fitted))

3.2 Pin Headers

All the pin headers are set on a 2.54mm (0.1inch) pitch. To allow daughter boards to connect with the OEM-GPS board increased height board stacker connectors have been used. These connectors belong to the HW series manufactured by Samtec. A suitable cable assembly to mate with the CON1 is Samtec IDSD-05-D-04.00.

Note! Care should be taken if non-approved connectors are used with the HW series connectors as the stacker bar can be pushed down.

3.3 Aux Power In Connector

The AUX power connector is a two-pin screw terminal (5mm pitch), capable of accepting a maximum wire size of 2.5mm².

Filename	UWEBL_DM.DOC	Document Revision	1.7
Date of Issue	29 March 2007	Page Number	Page 10 of 71

3.4 Antenna Connector

The GR47/48 engine uses a micro-miniature coaxial MMCX connector. Comtech offers various solutions to convert this to a more useable SMA connector, see section 5 - Comtech MMCX to SMA Cables.

3.5 Antenna

The antenna transmits and receives electromagnetic energy between the module and the network and its efficient function depends on the type of and placement of the antenna and communication disturbances in the vicinity in which it operates. It is therefore important that the following details are considered when selecting the antenna.

3.5.1 Antenna Type

- the antenna must be designed for dual frequency band use
 - E-GSM900/GSM1800 for the GR47
 - GSM850/GSM1900 for the GR48
- the combined impedance of the antenna and cable must be 50ohms
- the antenna output power handling must be a minimum of 2W.
- the VSWR value should be less than 3:1 to avoid damage to the radio device.

3.5.2 Antenna Placement

- the antenna should be placed away from other antennas (by min 50cm) and electronic devices
- if the signal strength is weak then a direction antenna placed facing the closest radio base station should improve performance.
- the modules peak output power of 2W can equate to a field strength of 70V/m at 10cm distance from the antenna. At 1metre this had dropped to 7V/m. Since most CE-marked products for use in the home are rated to light industrial use of >3V/m this should be born in mind when locating the antenna if interference is to be avoided.

3.5.3 Antenna Cable

- Use 50ohm impedance low loss cable and high-quality impedance connectors with a frequency range of up to 2GHz to avoid RF losses and ensure that antenna cable is as short as possible.
- VSWR may depend on the antenna, cable and connectors. Use of an adapter/extension cable will also impact heavily on performance and the same selection criteria apply. It is recommended that these be avoided and that a suitable antenna/ cable combination be selected.

3.6 SIM Connector

The SIM connector is located on the underside of the module PCB.

Notes

1. *Before handling the SIM card in your application, ensure that you are not charged with static electricity. Use proper precautions to avoid electrostatic discharges. The module must be switched off before the SIM card is installed in your application.*
2. *When the SIM card hatch is opened, the SIM card connectors lie exposed under the SIM card holder. CAUTION: Do not touch these connectors! If you do, you may release an electrical discharge that could damage the module or the SIM card.*

Filename	UWEBL_DM.DOC	Document Revision	1.7
Date of Issue	29 March 2007	Page Number	Page 11 of 71

4 Header Descriptions

Refer to Figure 1 for header locations.

4.1 Power and Host Serial Header –CON1 (& CON7)

Pin	Name	I/O Type	Description
1	VIN	--	This input provides positive supply to the µWEB LITE GSM/GPRSE. The power supply connected to this pin must be meet the criteria as stated in this manual. (5V-15VDC)
2	DGND	--	This input provides the supply return (0 Volts). All measurements with regards to supply voltages should be made reference to this pin.
3	RXD	TTL/RS232	Output used to transmit the data from the modem to the host at the selected baud rate.
4	TXD	TTL/RS232	Input used to receive data from the host to the modem at the selected baud rate.
5	/DTR	TTL/RS232	Is used by the host device to indicate that the host is ready to communicate.
6	/DCD	TTL/RS232	This control line is often used to indicate a connection with the remote modem.
7	/RTS	TTL/RS232	Is used to halt data from the modem should the host internal buffers become full and is cleared when the buffers have emptied sufficiently for transmission to resume.
8	/CTS	TTL/RS232	Is used to halt data from the host should the modem internal buffers become full and is cleared when the buffers have emptied sufficiently for transmission to resume.
9	/RI	TTL/RS232	This control line indicates the presence of an incoming call. The line will SET when the RING commences and remain SET throughout the RING events. Once the call is disconnected the line will return to CLEAR.
10	/RESET	Identical for both TTL and RS232 version	This input resets the module. Under normal conditions this pin is either left floating or held at > 3.3 volts (15 volts max). If this input is taken to 0 volts the onboard microprocessor will restart the GPRS Module. If a RESET is performed this input must be held at 0 volts for at least 500mS. (see note 1.3.1). This pin has an internal 22k pull up resistor to +3.3 volts and is diode protected against higher voltage inputs.

The main communication with the module takes place via CON1. This connector hosts power, data lines and /RESET. A version of the modem is available which has CON1 connector re-located to the bottom-side of the board; in this instance the connector is termed CON7.

Depending on the modem options the communication with the unit will use either RS-232 or TTL levels.

4.1.1 /RESET

The modem contains a reset system, which will generate an internal /RESET signal under the following conditions:

- CON1-pin 10 being taken low for a minimum of 500mSec and then released,
- On-board 3.3V supply dropping below a pre-determined level,

Filename	UWEBL_DM.DOC	Document Revision	1.7
Date of Issue	29 March 2007	Page Number	Page 12 of 71

- Power being applied to the board.

The signal placed on CON1-10 is taken via a series diode before being pulled to 3.3V via a 22k resistor.

When CON1-10 is taken low, a valid reset condition is entered, the on-board /RESET signal will be held low for a minimum of 140mSec after CON1-10 is released.

CON1-10 can be used to generate a reset by pulling the line low and then releasing it, using either a push button or open collector transistor for example.

4.1.2 DGND

Note! *AGND and DGND are connected at a star point inside the GR47/48 engine. They must not be joined together in your application.*

Notes

1. All control and data lines are labelled with reference to the HOST (DTE)
2. CON1 is fitted as standard. CON7 is an option fit.
3. The function of RTS and CTS can be set by the AT+IFC command. This command also allows software flow control (XON / XOFF).
4. Signals are 3v TTL volt logic. All inputs are protected and will accept up to 5v TTL logic levels. Control lines are SET at 0 volts and CLEAR at 3 volts.
5. If software flow control (XON / XOFF) is used the hardware control lines must be held in the SET state. If the µWEB LITE GSM/GPRS is controlled from a Windows application or system it is recommended that hardware flow control is used.
6. For the RS232 variant /RESET is not level shifted and the same interface criteria apply to the host if this input is to be controlled.

4.2 AUX Power In – CON6

Pin	Name	Description
1	DGND	This input provides the supply return (0 Volts). All measurements with regards to supply voltages should be made reference to this pin.
2	VIN	This input provides positive supply to the µWEB LITE GSM/GPRS. The power supply connected to this pin must be meet the criteria as stated in this manual.

Note! *Supply of power using CON1/CON7 connector is not recommended for ribbon cable length great than 8cm. For longer cable runs the AUX Power In connector CON6 must be used, and suitable cable selected.*

Filename	UWEBL_DM.DOC	Document Revision	1.7
Date of Issue	29 March 2007	Page Number	Page 13 of 71

4.3 Audio Header – CON5

Pin	Name	Dir	IO Type*	Description
1	BUZZER	OUT	4	Buzzer output
2	MICP	IN	5	Microphone positive input
3	MICN	IN	5	Microphone negative input
4	BEARP	OUT	5	Speaker positive output
5	BEARN	OUT	5	Speaker negative output
6	AGND			Ground (return) for analogue audio
7	ATMS	IN	5	Audio to mobile station
8	RESERVED	N/A	--	DO NOT USE
9	AFMS	OUT	5	Audio from mobile station
10	Ext PSU out	Supply OUT	--	This is a filtered version of the user's supply(5-15VDC)

Note! *AGND and DGND are connected at a star point inside the GR47/48 module. They must not be joined together elsewhere.*

ATMS is the audio input, and AFMS is the audio output, of the module. These signals can be used in Hands-free or Portable Hands-free mode.

Hands-free Mode

This mode is used for audio accessories, such as car kits and hands-free equipment.

Portable Hands-free Mode

This is the default mode. It activates a different amplification factor in the ME, and activates a 2V microphone bias level for ATMS. The bias level is adjustable using AT*E2EAMS.

4.3.1 Audio To Mobile Station – ATMS

ATMS is the analogue audio input to the module. Internally, the signal is sent to the CODEC (COder/DECoder), where it is converted to digital audio in PCM (Pulse Code Modulation) format. The encoded audio is sent to PCMOUT via the internal PCM bus.

ATMS provides a DC bias when it is used as the microphone input in Portable Hands-free applications. All other sources must be a.c.-coupled to avoid attenuation of low frequencies, and to prevent incorrect biasing or damage to the ATMS input. Use a capacitor greater than the value shown in the table below.

The ATMS input is a passive network followed by the transmit part of the CODEC.

Filename	UWEBL_DM.DOC	Document Revision	1.7
Date of Issue	29 March 2007	Page Number	Page 14 of 71

Parameter		Limit
Application driving impedance (0.3 - 3.5kHz)		≤300Ω
AC coupling capacitance ¹		≥1µF
Module input impedance (0.3 - 3.5kHz)		>50kΩ
Low frequency cut-off (-3dB)		300Hz ± 50Hz
High frequency cut-off (-3dB)		>3500Hz ± 50Hz
Output d.c. bias level	Hands-free mode	0V
	Portable hands-free mode	2.0V ± 0.1V
Additional Gain in Portable hands-free mode		28.5dB

¹ The a.c.-coupling capacitance must be supplied by your application, unless a d.c.-coupled microphone is used.

The following tables show the nominal PGA (programming gain settings). For more information see the relevant AT commands.

Maximum input voltage limit: 245mV_{rms}

Input	Input (mV _{rms})	TXAGC(dB)	AUX AMP gain	PCMOUT (dBm0)
ATMS	245	0	13	3

Maximum input level at MICI, 61.4mV_{rms} output at PCMOUT = 3dBm0

Input	Differential Input (mV _{rms})	TXAGC(dB)	AUX AMP gain	PCMOUT (dBm0)
MICN/MICP	61.4	0	25	3

Output at AFMS for 3dBm0 at PCMIN

Input	dBm0	RXPGA	Volume Control (dB)	AFMS(mV _{rms})
PCMIN	3	0	0	436

Output at BEARN/BEARP for 3dBm0 at PCMIN

Input	dBm0	RXPGA	Volume Control (dB)	BEAR(mV _{rms})
PCMIN	3	0	0	388

4.3.2 Audio From Mobile Station - AFMS

AFMS is the analogue audio output from the module and may be used to drive a speaker or the earpiece in a portable hands-free accessory.

The table below shows the audio signal levels for AFMS.

Filename	UWEBL_DM.DOC	Document Revision	1.7
Date of Issue	29 March 2007	Page Number	Page 15 of 71

Parameter		Limit
Speaker impedance		64Ω to 1KΩ
Output Capacitance		2.2μF ± 10%
Levels (THD <5%)	Drive capability into 5kΩ (0.3 to 3.5kHz)	> 2.4 V _{p-p}
	Drive capability into 1.5kΩ (0.3 to 3.5kHz)	> 2.2 V _{p-p}
	Drive capability into 150Ω (at 1kHz)	> 1.3 V _{p-p}

4.4 Microphone Signals

MICP and MICN are balanced differential microphone input pins. These inputs are compatible with an electret microphone. The microphone contains an FET buffer with an open drain output, which is supplied with at least +2V relative to ground by the module as shown below.

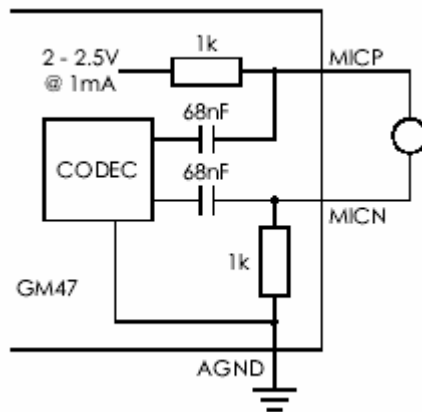

Figure 2: Microphone connections to module

4.4.1 Speaker Signals

BEARP and BEARN are the speaker output pins. These are differential-mode outputs. The electrical characteristics are given in the table below.

Parameter	Limit
Output level (differential)	≥ 4.0 V _{p-p}
Output level (dynamic load = 32Ω)	≥ 2.8 V _{p-p}
Gain PCMIN to BEARP/BEARN (differential)	-9dB ± 1
Distortion at 1kHz and maximum output level	≤ 5%
Offset, BEARP to BEARN	± 30mV
Ear-piece mute-switch attenuation	≥ 40 dB

The following table shows the earpiece impedances that can be connected to BEARP and BEARN.

Filename	UWEBL_DM.DOC	Document Revision	1.7
Date of Issue	29 March 2007	Page Number	Page 16 of 71

Ear Piece	Impedance	Tolerance
Dynamic ear piece	[32Ω + 800 µH] // 100 pF	± 20%
Dynamic ear piece	[150Ω + 800 µH] // 100 pF	± 20%
Piezo ear piece	1kΩ + 60 nF	± 20%

4.5 I/O Header – CON2

Pin	Name	Dir	IO Type*	Description
1	Ext PSU out	Supply OUT	-	This is a filtered version of the user's supply(5-15VDC)
2	GND	Supply	-	
3	uP I/O 0	IN/OUT	2	Bi directional user IO 0
4	uP I/O 1	IN/OUT	2	Bi directional user IO 1
5	uP I/O 2	IN/OUT	2	Bi directional user IO 2
6	uP I/O 3	IN/OUT	2	Bi directional user IO 3
7	uP I/O 4	IN/OUT	2	Bi directional user IO 4
8	uP I/O 5	IN/OUT	2	Bi directional user IO 5
9	uP I/O 6	IN/OUT	2	Bi directional user IO 6
10	uP I/O 7	IN/OUT	2	Bi directional user IO 7
11	uP Input 8	IN	3	analogue input channel 0
12	uP Input 9	IN	3	analogue input channel 1
13	uP Input 10	IN	3	analogue input channel 2
14	uP Input 11	IN	3	analogue input channel 3
15	Reserved	N/A	-	Do not use
16	Reserved	N/A	-	Do not use
17	Reserved	N/A	-	Do not use
18	Reserved	N/A	-	Do not use

* see details in section 10

4.6 Interface Header – CON3

Note! *The information in this section is provided for reference. The signals on this header are not under the control of the end-user.*

CON3 is a multi-purpose Header. The individual features of this connector are detailed below in the relevant sub-sections.

Filename	UWEBL_DM.DOC	Document Revision	1.7
Date of Issue	29 March 2007	Page Number	Page 17 of 71

4.6.1 GPS interface (checked against µWEB Lite schematics)

Pin	Name	Direction	IO Type*	Description
1	Ext PSU out	Supply OUT	-	This is a filtered version of the user's supply(5-15VDC)
2	RESERVED	-	-	DO NOT USE
3	RESERVED	-	-	DO NOT USE
4	RESERVED	-	-	DO NOT USE
5	RESERVED	-	-	DO NOT USE
6	RESERVED	-	-	DO NOT USE
7	GPS RX	INPUT	1	GPS module receive data
8	GPS TX	OUT	1	GPS module transmit data
9	GPS EN	OUT	1	GPS module enable
10	/RESET	OUTPUT	-	GPS/RESET control
11	3V3	SUPPLY	-	3.3V output
12	GND	SUPPLY	-	Ground

** please refer to section 10 for details*

4.7 Network Status & RTC – CON4

Pin	Name	Direction	Description
1	Not Used		
2	Not Used		
3	GSM LED ANODE	OUT	Provides current feed to anode of external GSM status LED
4	GSM LED CATHODE	IN	Provides return path from cathode of external GSM LED
5	Not Used		
6	Not Used		
7	VRTC	Supply	RTC back up supply
8	GND	Supply	RTC supply ground

The GPRS module has an on-board GREEN LED. However, an external LED can be connected to CON4.

LED indication	Operational status
Off	No power or in the OFF state
Steady	Power on, not connected to a network
Blinking	Power on, connected to a network

Filename	UWEBL_DM.DOC	Document Revision	1.7
Date of Issue	29 March 2007	Page Number	Page 18 of 71

V_{RTC} is supplied directly to the on-board RTC (if fitted). The RTC is supplied from an on-board 3v3 regulator. If the output from this regulator should fall below the voltage on V_{RTC} the RTC will be write-protected. The RTC is fully accessible when the 3v3 voltage is greater than $V_{RTC}+0.2V$.

Note! *V_{RTC} should be supplied from a non-rechargeable Lithium Battery or other suitable power source with a voltage in the range 1.8V-5.5VDC. There is no facility for charging the source.*

4.8 GSM/GPRS Antenna Connector

The module's antenna connector allows transmission of the radio frequency (RF) signals from the module to an external antenna. The connector is a micro-miniature coaxial MMCX surface mounted component. A number of suitable MMCX type, mating plugs are available from the following manufacturers:

- Amphenol;
- Suhner;
- IMS Connector Systems.

The electrical characteristics of the antenna interface are shown below.

Filename	UWEBL_DM.DOC	Document Revision	1.7
Date of Issue	29 March 2007	Page Number	Page 19 of 71

Parameter	Limit	Description
Nominal impedance	50Ω (better than 2:1)	
Output Power	2 Watt peak (Class 4)	Extended GSM900
	1 Watt peak (Class 1)	GSM1800
Static Sensitivity	Better than -104dBm	Extended GSM900
	Better than -102dBm	GSM1800

Comtech sell a number of antennas with MMCX terminations and also a range of adapter cables to convert from the MMCX to a SMA connector.

5 Comtech MMCX to SMA Cables

The Ericsson GR47/48 engine utilise a MMCX (micro-miniature coaxial) for the antenna connector. Due to the small size of these connectors COMTECH have manufactured a number of cable assemblies to allow the use of SMA type connectors. These are ordered separately and details are given below.

5.1 Cable-004

This cable assembly consists of a right-angled MMCX plug, a 40mm RG316 cable and a PCB mount SMA Jack. The SMA connector is designed to mount directly to the μWEB LITE GSM/GPRS PCB.

5.2 Cable-018

This assembly consists of a right-angled MMCX plug, a 175mm RG316 cable and a bulkhead mounted SMA Jack.

Filename	UWEBL_DM.DOC	Document Revision	1.7
Date of Issue	29 March 2007	Page Number	Page 20 of 71

6 GSM Characteristics

The µWEB Lite family of intelligent modems use dual band mobile stations with the characteristics shown in the tables below.

6.1 µWEB Lite GSM/GPRS EUR (for Europe)

	E-GSM900	GSM1800
Frequency range (MHz)	TX: 880 – 890 RX: 925 – 935	TX: 1710 – 1785 RX: 1805 – 1880
Channel spacing	200kHz	200kHz
Number of channels	174 carriers * 8 time slots (TDMA) GSM: channels 1 to 124 E-GSM: channels 975 to 1023	374 carriers *8 (TDMA) DCS: channels 512 to 885
Modulation	GMSK	GMSK
TX phase accuracy	<5° RMS phase error (burst)	<5° RMS phase error (burst)
Duplex spacing	45 MHz	95 MHz
Receiver sensitivity at antenna connector	<-102dBm	<- 102dBm
Transmitter output power at antenna connector	Class 4 2W (33dBm)	Class 1 1W (30dBm)
Automatic hand-over between GSM900 and GSM1800		

6.2 µWEB Lite GSM/GPRS FCC (for USA)

Contact Comtech Holdings Ltd for further details of this variant

	GSM950	GSM1900
Frequency range (MHz)	TX: 824 – 849 RX: 869 - 894	TX: 1850 - 1910 RX: 1930 – 1990
Channel spacing	200kHz	200kHz
Number of channels	124 carriers * 8 time slots (TDMA) GSM: channels 128 to 251	299 carriers * 8 time slots (TDMA) PCS: channels 512 to 810
Modulation	GMSK	GMSK
TX phase accuracy	<5° RMS phase error (burst)	<5° RMS phase error (burst)
Duplex spacing	45 MHz	80 MHz
Receiver sensitivity at antenna connector	<-102dBm	<- 102dBm
Transmitter output power at antenna connector	Class 4 2W (33dBm)	Class 1 1W (30dBm)
Automatic hand-over between GSM850 and GSM1900		

Filename	UWEBL_DM.DOC	Document Revision	1.7
Date of Issue	29 March 2007	Page Number	Page 21 of 71

7 Functional Description

7.1 Firmware

In order to fulfill cost sensitive applications, the μWeb Lite has been designed using a small, low cost microprocessor. As a result, several firmware builds are available in order to provide a wide range of functionality. These builds are known as "SMTP Client", "FTP Client" and "Automated". An overview of each is presented in the following paragraphs. Firmware builds may be changed by the end user using the PC configuration tool. Modules are shipped with the SMTP client build pre-loaded.

7.1.1 SMTP Client (Email)

Simple Mail Transfer Protocol (SMTP) is used for sending emails. The SMTP client build implements the sending of an email stored in non-volatile memory, together with an optional attachment, also stored in non-volatile memory. The email content, and attachment content are pre-stored, after which the AT#SMTP command is issued.

Full details, together with an example, are described in http://www.comtech.uk.com/Downloads/μWEBLite/AppNotes/email_3E.pdf

7.1.2 FTP Client (File Transfer)

File Transfer Protocol (FTP) is used for sending files to or from a server. The FTP client build implements the sending and receiving of data stored in non-volatile memory, or to/from a serial port. An additional option is to have the source file on the server automatically deleted upon successful completion of the download.

Full details, together with examples, are described in http://www.comtech.uk.com/Downloads/μWEBLite/AppNotes/ftp_3E.pdf

7.1.3 Automated

The automated firmware allows the μWEB Lite to perform a variety of automated actions without the need for a host. Automated actions are initiated by configurable wakeup sources. Prior to a valid wakeup source, the μWEB Lite is configured to minimise power consumption, this state is referred to as the low power mode. The amount of power consumed in low power mode is dependant on the wakeup sources selected (refer to section 7.1.3.3).

The flowchart in figure 7.1 shows the automate firmware process flow on power on/reset of the μWEB Lite. The flowchart highlights how DTR is used to place the unit into command mode. This allows the user to configure the unit. If there are no automated actions selected, the unit functions as a standard GSM/GPRS modem.

Once the μWEB Lite has entered low power mode, only a valid wakeup source or a power cycle/reset can exit this mode. If unit is power cycled or reset when low power mode is active, the process flow is as outlined in figure 7.1. If a valid wakeup source is received when low power mode is active, the process flow is as outlined in figure 7.2.

Filename	UWEBL_DM.DOC	Document Revision	1.7
Date of Issue	29 March 2007	Page Number	Page 22 of 71

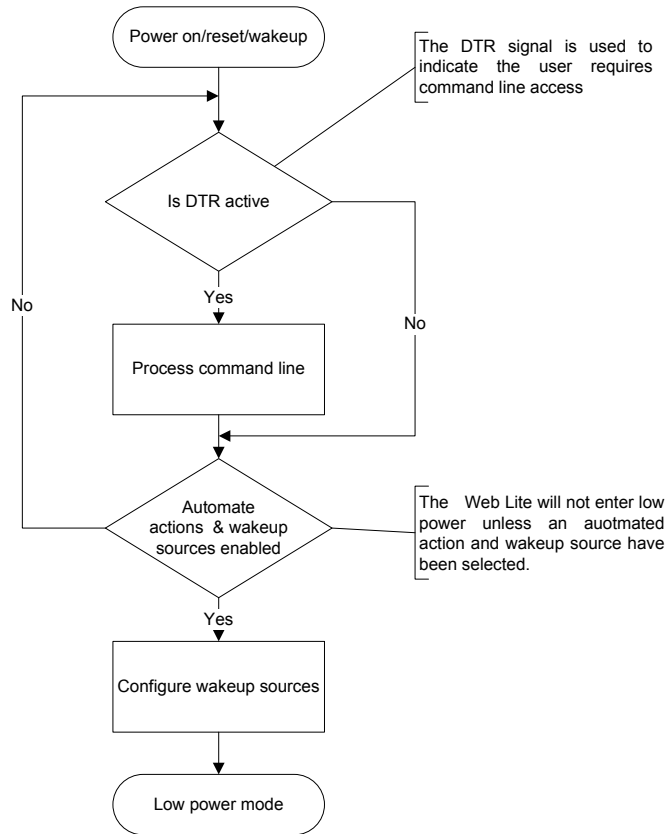

Figure 7.1 Power on/reset program flow

7.1.3.1 Automated Actions

There are currently seven automated actions (sometimes referred to as automated modes) currently supported on the μWEB Lite as detailed below. The automated action is configured using the AT#MO command. Automated actions are initiated only when a valid wakeup source occurs. The flowchart in figure 7.2 details the process to initiate an automated action.

If the 'mode complete response' bit is set in the Configuration Bitmap register (refer to section 8.9.1) then the either 'OK' or 'ERROR' is produced to indicate whether the automated action was successful.

MODE 0. None

In this mode the μWEB Lite will operate as a normal GSM/GPRS modem.

MODE 1. Timers only

In this mode the μWEB Lite will remain in low power mode until a valid wakeup source has been detected. Once awake, no automated action will be performed however both the command mode and start/end timers are active. This mode is used to conserve power.

Filename	UWEBL_DM.DOC	Document Revision	1.7
Date of Issue	29 March 2007	Page Number	Page 23 of 71

MODE 2. Send SMS message

In this mode the μWEB Lite will send an SMS when a valid wakeup source has been detected. Before sending the SMS, the μWEB Lite will check the network registration status. If the unit fails to register onto the network after 5 minutes the automated action is cancelled and both the command mode and start/end timers (refer to section 7.1.3.2) are active.

The content of the SMS is configured using AT#SMS command (refer to section 8.9.12). The current I/O and ADC values can also be appended to the outgoing SMS (refer to section 8.9.1). There are three possible destinations for the automated SMS these are listed in priority:

1. Autodial number0 (AT#D0, refer to section 8.9.3)
2. Autodial number1 (AT#D1, refer to section 8.9.3)
3. The source of the wakeup. This option is only available if the wakeup source is either an incoming validated SMS or Number matching on incoming call

Once the SMS has been sent, both the command mode and start/end timers (refer to section 7.1.3.2) are active. Application notes on sending automated SMS are available at:

http://www.comtech.uk.com/Downloads/uWebLite/AppNotes/adc_sms.pdf

http://www.comtech.uk.com/Downloads/uWebLite/AppNotes/cli_sms.pdf

http://www.comtech.uk.com/Downloads/uWebLite/AppNotes/lo_sms.pdf

http://www.comtech.uk.com/Downloads/uWebLite/AppNotes/Ring_sms.pdf

http://www.comtech.uk.com/Downloads/uWebLite/AppNotes/rtc_sms.pdf

Filename	UWEBL_DM.DOC	Document Revision	1.7
Date of Issue	29 March 2007	Page Number	Page 24 of 71

MODE 3. Send SMS with GPS position

In this the mode the µWEB Lite will send an SMS with the GPS position, when a valid wakeup source has been detected. This automated mode is only supported on the µWEBBox Lite with the GPS option installed. Before sending the SMS, the µWEB Lite will check the network registration status. If the unit fails to register onto the network after 5 minutes the automated action is cancelled and both the command mode and start/end timers are activate.

The content of the SMS will be the standard NMEA - Recommended Minimum Specific GPS/TRANSIT (GPRMC) string. The format of the GPRMC string is:

\$GPRMC,hhmmss.ss,A,llll.ll,a,yyyyy.yy,a,x.x,x.x,ddmmyy,x.x,a,m*hh

Where:

Field	Description
1	UTC time of fix
2	Data status (A=Valid position, V=Navigation receiver warning)
3	Latitude of fix
4	N or S of longitude
5	Longitude of fix
6	E or W of longitude
7	Speed over ground in knots
8	Track made good in degrees True
9	UTC date of fix
10	Magnetic variation degrees (Easterly var. subtracts from true course)
11	E or W of magnetic variation
12	Mode indicator, (A=Autonomous, D=Differential, E=Estimated, N=Data not valid)
13	Checksum

The current I/O and ADC values can also be appended to the outgoing SMS (refer to section 8.9.1). There are three possible destinations for the automated SMS these are listed in priority:

1. Autodial number0 (AT#D0, refer to section 8.9.3)
2. Autodial number1 (AT#D1, refer to section 8.9.3)
3. The source of the wakeup. This option is only available if the wakeup source is either an incoming validated SMS or Number matching on incoming call

Once the SMS has been sent both the command mode and start/end timers (refer to section 7.1.3.2) are activate.

MODE 4. Autodial

In this the mode the µWEB Lite will autodial a number when a valid wakeup source has been detected. Before dialling the µWEB Lite will check the network registration status. If the unit fails to register onto the network after 5 minutes the automated action is cancelled and both the command mode and start/end timers are active.

There are three possible autodial number these are listed in priority:

1. Autodial number0 (AT#D0, refer to section 8.9.3)
2. Autodial number1 (AT#D1, refer to section 8.9.3)
3. The source of the wakeup. This option is only available if the wakeup source is either an incoming validated SMS or Number matching on incoming call

Once the call is complete, the command mode and start/end timers (refer to section 7.1.3.2) are active. An application note on autodial is available at:

http://www.comtech.uk.com/Downloads/uWebLite/AppNotes/dtr_dial.pdf

Filename	UWEBL_DM.DOC	Document Revision	1.7
Date of Issue	29 March 2007	Page Number	Page 25 of 71

MODE 5. Autodial with Piped GPS

In this the mode the μWEB Lite will autodial a number when a valid wakeup source has been detected. Before dialling the μWEB Lite will check the network registration status. If the unit fails to register onto the network after 5 minutes the automated action is cancelled and both the command mode and start/end timers are active.

There are three possible autodial number these are listed in priority:

1. Autodial number0 (AT#D0, refer to section 8.9.3)
2. Autodial number1 (AT#D1, refer to section 8.9.3)
3. The source of the wakeup. This option is only available if the wakeup source is either an incoming validated SMS or Number matching on incoming call

Once the call has been established the unit will continuously send the GPRMC string (refer to mode 3) until the call is terminated. Once the call is complete, both the command mode and start/end timers (refer to section 7.1.3.2) are active.

MODE 6. Auto Connect to TCP Socket

In this the mode the μWEB Lite will connect to a TCP server socket, when a valid wakeup source has been detected. Before dialling the μWEB Lite will check the network registration status. If the unit fails to register onto the network after 5 minutes the automated action is cancelled and both the command mode and start/end timers are active.

Refer to section 8.5 for details on TCP socket configuration. Once the TCP socket has closed, the command mode and start/end timers (refer to section 7.1.3.2) are active. An application note for auto-connect TCP socket is available at:

http://www.comtech.uk.com/Downloads/uWebLite/AppNotes/rxd_tcp.pdf
http://www.comtech.uk.com/Downloads/uWebLite/AppNotes/sms_tcp.pdf
http://www.comtech.uk.com/Downloads/uWebLite/AppNotes/sms_tcp.pdf

MODE 7. Auto Connect to TCP Socket with Piped GPS

In this the mode the μWEB Lite will connect to a TCP server socket, when a valid wakeup has been detected. Before dialling the μWEB Lite will check the network registration status. If the unit fails to register onto the network after 5 minutes the automated action is cancelled and both the command mode and start/end timers are active.

Refer to section 8.5 for details on TCP socket configuration. Once the TCP socket is open, the unit will continuously send the GPRMC string (refer to mode 3) until the socket is closed. Once the socket is closed, the command mode and start/end timers (refer to section 7.1.3.2) are active.

Filename	UWEBL_DM.DOC	Document Revision	1.7
Date of Issue	29 March 2007	Page Number	Page 26 of 71

7.1.3.2 Start and Stop timers

The start and stop timers are used to specify the maximum period of inactive communication between the host and the μWEB Lite before the unit returns to low power mode. Communication between the host and the μWEB Lite includes characters both transmitted and received, DTR active or an active call. The function of each timer is detailed below. The flowchart in figure 7.2 shows how the start and stop timers interact.

Start Timer

After an automated action, the start timer is activated. If the start timer expires before a data connection, DTR or data to/from the host has been detected, the μWEB Lite will enter power down state again. If a data connection, DTR or data to/from the host is detected before the start timer expires, then the end timer is activated.

End timer

The end timer is started after the termination of the START timer. If the end timer expires before a data connection, DTR or data to/from the host has been detected, the μWEB Lite will enter power down state again. If a data connection, DTR or data to/from the host is detected before the end timer expires, then the end timer is reset.

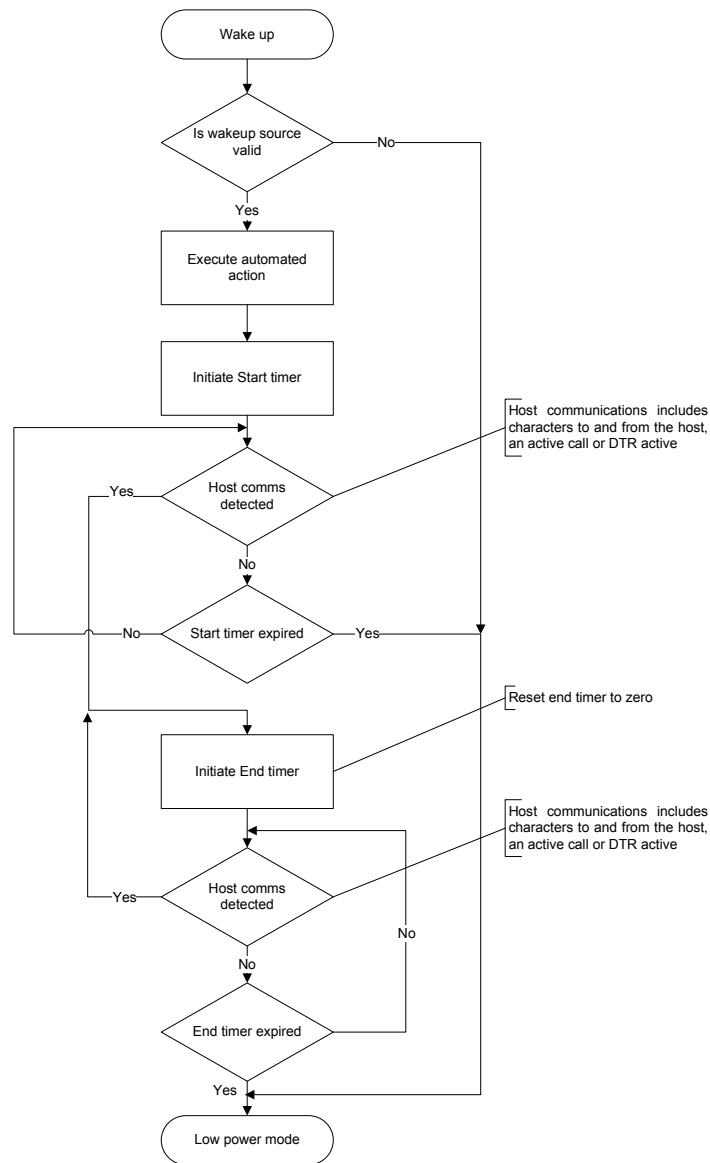

Figure 7.2: Start and Stop timers

Filename	UWEBL_DM.DOC	Document Revision	1.7
Date of Issue	29 March 2007	Page Number	Page 27 of 71

7.1.3.3 Wakeup Sources

The wakeup sources (sometimes referred to as trigger sources) are used to wake the μWEB Lite from the low power mode and carry out the automated action selected (refer to section 7.1.3.1). There are currently 8 wakeup sources supported, which are bitmapped therefore more than one wakeup source may be specified. The wakeup source are configured using the AT#WAK command (refer to section 8.2.2).

Bit 0 – Reserved

Bit 1 – Host data received.

This bit allows the host to send a single character to initiate a wakeup. It currently takes 500 msec for the unit to exit low power mode, any characters received during this time will not be captured by the unit.

Bit 2 – Real Time Clock Alarm.

This bit allows the host to configure the real time clock alarm to initiate a wakeup. The alarm is cleared (if set) before entering low power mode.

Bit 3 – ADC Threshold Exceeded

This bit allows the host to periodically check whether any ADCs have exceeded their associated upper or lower thresholds.

Bit 4 – Incoming RING.

This bit allows an incoming call to initiate a wakeup. In this mode the GSM/GPRS receiver remains powered. The automated action is only initiated once the ring has finished.

Bit 5 – Number match on incoming call

This bit allows an incoming call with number matching any of the call matching numbers to initiate a wakeup. In this mode the GSM/GPRS receiver remains powered. The automated action is only initiated once the ring finished.

Bit 6 – Incoming SMS

This bit allows an incoming SMS message, which contains a valid username and password to initiate a wakeup. In this mode the GSM/GPRS receiver remains powered.

Bit 7 – I/O State Change

This bit allows any state change on IO0-IO7 (μWEB Lite) or IO0-IO1 (μWEBBox Lite) to initiate a wakeup.

Filename	UWEBL_DM.DOC	Document Revision	1.7
Date of Issue	29 March 2007	Page Number	Page 28 of 71

8 Host Interface

At power up, the μWEB Lite GSM/GPRS is in the AT Command mode. AT commands begin with the letters AT, end with a carriage return, and are case insensitive. However, case cannot be mixed in a single command. The only exception to this format is the A/ command. This command is neither preceded by AT nor followed by a carriage return but re-executes the previous command immediately when the “/” character is typed.

8.1 Extended AT# Commands

In addition to supporting all the usual GSM & GPRS modem features as detailed in the “μWEBμWEB Lite AT Commands Manual”, the μWEB Lite modem features an external controller/driver, which supports additional enhanced features. This section details all the extended AT# commands used to access the enhanced μWEB Lite features. Within this section, the extended commands are grouped into the following categories:

- | | | |
|---|---|----------------------------------|
| <ul style="list-style-type: none"> • SMTP client • FTP client • Automated | } | Firmware specific |
| <ul style="list-style-type: none"> • TCP socket client • Filing system • I/O and ADC monitoring • GPS • Configuration • General | } | Available in all Firmware builds |

All extended AT# commands are accessible via three different interfaces

1. Local – The local command line interface is normally connected directly to the host. Unlike the other two options, this interface requires the baud rate of the μWEB Lite and host to match.
2. Remote – To access the remote command line interface, the μWEB Lite or associated host must answer the incoming call. The μWEB Lite can be configured to auto answer incoming calls by setting S register 0 to a value other than zero. **Note the bootloader validates an incoming call using two rings, therefore if remote updates are required S register 0 must be set to answer on 3 rings or higher.** Once a connection is established to gain access to the command line, send ‘---’, preceded by a pause of at least one second. The μWEB Lite will response remotely with ‘OK’ to indicate the remote command line is now active. To return to normal data transfer use the AT#O command (refer to section 9).
3. SMS – This command line interface is only accessible when the unit is in a low power mode and configured to wakeup on an incoming, validated, SMS. The SMS must have the following format:

`username password >cmd1[cmd2]..[cmdN]`

where:

- *username* and *password* must match the at#usr and at#pwd settings respectively of the module (see sections 8.2.6 and 8.2.5). **Note** - the username and password **must** contain alphanumeric characters only.
- The *username* and *password* **must** each be followed by a **single** space character.

Filename	UWEBL_DM.DOC	Document Revision	1.7
Date of Issue	29 March 2007	Page Number	Page 29 of 71

- The command list **must** be immediately preceded by a > character with **no** space character after it.
- *cmdn* is the command to be executed and begins with the # character (*at* is implied and **must** not be included). Multiple commands can be concatenated in a single SMS.
- The total message length **must** not exceed the 160 character limit of an SMS message.

Note – only at# commands can be processed and even then, commands that would require a network connection (eg at#tcp) cannot be processed since the modem is already connected to the network.

For example, if the module's SMS username and password were set to *myusername* and *mypassword* respectively, the following SMS would cause the sequence:

- set all I/O lines to outputs
- set outputs 0, 2, 3 and 5 to 1 and all others to 0
- wait 5 seconds
- set all the outputs to 0

```
myusername mypassword >#ioc=00#iow=4D#pau=5#iow=00
```

(see section 8.7 for details of the IO commands)

Filename	UWEBL_DM.DOC	Document Revision	1.7
Date of Issue	29 March 2007	Page Number	Page 30 of 71

8.2 Automated

The automated firmware build allows the μWEB Lite to perform a variety of automated actions with or without a host (refer to section 7.1.3). This section details the commands required to configure automated actions.

8.2.1 AT#MO Automated mode of operation

Description	Command	Possible responses
Set the mode of operation	AT#MO=<MODE>	<ul style="list-style-type: none"> ERROR OK
Read the current setting	AT#MO?	<MODE>

<MODE>	Description
0	No automated action (normal modem functionality).
1	Enter low power mode until wake source detected. Activate start and end timers only
2	Enter low power mode until wake source detected. Send the static SMS message (#SMS) to either: <ul style="list-style-type: none"> Autodial number0 (#D0), if configured. Autodial number1 (#D1), if configured. Remote host (if available and neither Autodial numbers are configured). Activate start and end timers.
3	Enter low power mode until wake source detected. Send the SMS message containing GPRMC string to either: <ul style="list-style-type: none"> Autodial number0 (#D0), if configured. Autodial number1 (#D1), if configured. Remote host (if available and neither Autodial numbers are configured). Activate start and end timers.
4	Enter low power mode until wake source detected. Establish data connect to remote unit using either: <ul style="list-style-type: none"> Autodial number0 (#D0), if configured. Autodial number1 (#D1), if configured. Remote host (if available and neither Autodial numbers are configured). After the call has terminated activate start and end timers.
5	Enter low power mode until wake source detected. Establish data connect and transmit output from the GPS unit to remote unit using either: <ul style="list-style-type: none"> Autodial number0 (#D0), if configured. Autodial number1 (#D1), if configured. Remote host (if available and neither Autodial numbers are configured). After the remote end has terminated activate start and end timers.
6	Enter low power mode until wake source detected. Establish TCP socket connection After the call has terminated activate start and end timers.

Filename	UWEBL_DM.DOC	Document Revision	1.7
Date of Issue	29 March 2007	Page Number	Page 31 of 71

8.2.2 AT#WAK Wakeup Source

Description	Command	Possible responses
Set wakeup source	AT#WAK=<WAKEUP>	<ul style="list-style-type: none"> • ERROR • OK
Read wakeup source	AT#WAK?	<WAKEUP>

This command configures the wakeup sources when automated mode is set to nonzero (refer to section 8.2). <WAKEUP> is entered and displayed in hexadecimal format.

<WAKEUP> bit	Description
0	DTR Active. This option allows the host DTR line to initiate a wakeup. On power cycle/reset the unit will remain awake whilst the host DTR is active.
1	Host data received. This option allows the host to send a single character to initiate a wakeup. It currently takes 500 msecs for the controller to leave low power mode, any character received as a wakeup source during this time will not be captured by the controller or GR47/48.
2	RTC Alarm0. This option allows the host to configure the real time clock's (RTC) alarm 0 to initiate a wakeup (refer to section 8.2.3). Alarm 0 is cleared (if set) before entering into low power mode
3	ADC Threshold Exceeded This option allows the host to configure the real time clock's (RTC) alarm 1, which is used to periodically check whether any ADCs have exceeded their associated upper or lower thresholds. This wake source requires both the configuration bitmap register (refer to section 8.9.1) and ADC thresholds (refer to sections 8.2.7 & 8.2.8) to be configured.
4	Incoming RING. This option allows an incoming call to initiate a wakeup. In this mode the GR47/48 remains powered. The automated action is only initiated once the ring has finished.
5	Number match on incoming call This option allows an incoming call with number matching any of the call matching numbers to initiate a wakeup. In this mode the GR47/48 remains powered. The automated action is only initiated once the ring finished.
6	Incoming SMS This option allows an incoming SMS message, which contains a valid username and password (refer to sections 1.1.1 & 8.2.6) to initiate a wakeup. In this mode the GR47/48 remains powered.
7	I/O State Change This option allows any state change on IO0-IO7 to initiate a wakeup

The table above illustrates, some wakeup sources require additional configuration. The additional configuration commands are detailed below.

Filename	UWEBL_DM.DOC	Document Revision	1.7
Date of Issue	29 March 2007	Page Number	Page 32 of 71

8.2.3 AT#AL Alarm Control

Description	Command	Possible responses
Set Alarm	AT#AL<ALARM ID>=<HH:MM:SS DOW DD>	<ul style="list-style-type: none"> • ERROR • OK
Read Alarm	AT#AL<ALARM ID>?	<ul style="list-style-type: none"> • <HH:MM:SS DOW DD> • OK

<ALARM_ID>	Description
Digit	Alarm identifier (0-1)

The µWEB Lite supports two real time clock alarms, Alarm 0 (AL0) and Alarm 1 (AL1). Both these alarms are used as wakeup sources.

Alarm 0 is used as the RTC Alarm (refer to sections 8.2.7 & 8.2.8). This option allows the host to configure Alarm 0 to initiate a wakeup.

Alarm 1 is used to check ADC thresholds (refer to section 8.2.7). This option allows the host to initiate a wakeup and periodically check whether any ADCs thresholds have been exceeded.

The Alarms can be configured to trigger on either:

Alarm Period	Alarm format
Once per month	<HH>:<MM>:<SS><SPACE><DOW> <DD>
Once per week	<HH>:<MM>:<SS><SPACE><DOW>
Once per day	<HH>:<MM>:<SS><SPACE>*
Once per hour	*:<MM>:<SS><SPACE>*
Once per minute	*:<SS><SPACE>*

Where:

HH	Hour (0-23)
MM	Minute (0-59)
SS	Seconds (0-59)
DOW	The day of the week: 0 – Sunday 1 – Monday 2 – Tuesday 3 – Wednesday 4 – Thursday 5 – Friday 6 – Saturday
DD	Day of the month (1-31)
*	Wildcard. The real time clock will ignore this value

Alarm strings must be within double quotes. The example below demonstrates how to configure the µWEB Lite to wakeup on the 25th minute of every hour:

Command	Description
AT#MO=1	When awake run start & end timers
AT#WAK=4<CR>	Configure wake up source as Alarm0
AT#AL0="*:25:00 * *"<CR>	Set Alarm 0 as hourly alarm (25 th minute, 0 seconds)

Filename	UWEBL_DM.DOC	Document Revision	1.7
Date of Issue	29 March 2007	Page Number	Page 33 of 71

8.2.4 AT#CMN Call matching number

Description	Command	Possible responses
Set call matching number	AT#CMN<CMN ID>="<MATCH_NUMBER>"	<ul style="list-style-type: none"> • ERROR • OK
Read call matching number	AT#CMN?	<ul style="list-style-type: none"> • <MATCH_NUMBER> • OK

<CMN_ID>	Description
Digit	Call matching number identifier (0-4)

<MATCH_NUMBER>	Description
String type	Number to match against

This command is used to configure the call matching numbers. There are five call matching numbers supported (<CMN ID>), these are matched against an incoming number when the *Number Match on Incoming Call* wakeup source has been selected (refer to section 7.1.3.3). In this mode the GSM/GPRS receiver remains powered. **The automated action is only initiated once the ring finished.**

Call matching numbers support the use of wild cards (*) to match digits at the start or end of an incoming number. Call matching number strings must be within double quotes. The maximum call matching number size is 20 digits.

The example below demonstrates how to configure the μWEB Lite to wake up when the remote calling device number start with "07771":

Command	Description
AT#MO=1	When awake run start & end timers
AT#WAK=20<CR>	Configure wake up source as caller id match
AT#CMN0="07771*"<CR>	Set call matching number 0 to 07771*

8.2.5 AT#PWD SMS Password

Description	Command	Possible responses
Set the SMS password	AT#PWD=<PASSWORD>	<ul style="list-style-type: none"> • ERROR • OK
Read the current setting	AT#PWD?	<PASSWORD>

The μWEB Lite can be configured to wakeup on an incoming SMS message (refer to section 7.1.3.3). To prevent SMS messages from the wrong source prompting an automated action, the SMS message can be validated against a username (AT#USR) (refer to section 8.2.6) and password.

The SMS password string must be within double quotes and no greater than 20 characters long. Valid SMS messages must contain the following string at the start of the message to trigger a wakeup:

<USERNAME><SPACE><PASSWORD><SPACE>...REST OF MESSAGE...

8.2.6 AT#USR SMS Username

Description	Command	Possible responses
Set SMS username	AT#USR="<USERNAME>"	<ul style="list-style-type: none"> • ERROR • OK
Read SMS username	AT#USR?	<USERNAME>

The μWEB Lite can be configured to wakeup on an incoming SMS message (refer to section 7.1.3.3). To prevent SMS messages from the wrong source prompting an automated action, the SMS message can be validated against a username and password (AT#PWD) (refer to section 1.1.1).

The SMS password string must be within double quotes and no greater than 20 characters long. Valid SMS messages must contain the following string at the start of the message to trigger a wakeup:

<USERNAME><SPACE><PASSWORD><SPACE>...REST OF MESSAGE...

Filename	UWEBL_DM.DOC	Document Revision	1.7
Date of Issue	29 March 2007	Page Number	Page 35 of 71

8.2.7 AT#THL Lower ADC threshold

Description	Command	Possible responses
Set lower ADC threshold	AT#THL<CHANNEL>= <LOWER THRESHOLD>	<ul style="list-style-type: none"> • ERROR • OK
Read lower ADC threshold	AT#THL?	< LOWER THRESHOLD>

This command configures the lower ADC threshold for the ADC channel specified. ADC thresholds can be used as a wakeup source (refer to section 7.1.3.3), when used in conjunction with the configuration bitmap register (refer to section 8.9.1).

When configured as a wakeup source, if the lower ADC threshold has been exceeded a wakeup event will occur, no other subsequent ADC threshold wakeup events will occur until the ADC returns within the threshold values.

<CHANNEL>	Description
0	ADC channel 0
1	ADC channel 1
2	ADC channel 2
3	ADC channel 3*

<LOWER THRESHOLD>	Description
0 – 3FF	Lower ADC threshold in hexadecimal format

*Note not supported on the μWEBox Lite.

8.2.8 AT#THU Upper ADC threshold

Description	Command	Possible responses
Set upper ADC threshold	AT#THU<CHANNEL>= <LOWER THRESHOLD>	<ul style="list-style-type: none"> • ERROR • OK
Read upper ADC threshold	AT#THU?	< UPPER THRESHOLD>

This command configures the upper ADC threshold for the ADC channel specified. ADC thresholds can be used as a wakeup source (refer to section 7.1.3.3), when used in conjunction with the configuration bitmap register (refer to section 8.9.1).

When configured as a wakeup source, if the upper ADC threshold has been exceeded a wakeup event will occur, no other subsequent ADC threshold wakeup events will occur until the ADC returns within the threshold values.

<CHANNEL>	Description
0	ADC channel 0
1	ADC channel 1
2	ADC channel 2
3	ADC channel 3*

<UPPER THRESHOLD>	Description
0 – 3FF	Upper ADC threshold in hexadecimal format

*Note not supported on the μWEBox Lite.

Filename	UWEBL_DM.DOC	Document Revision	1.7
Date of Issue	29 March 2007	Page Number	Page 36 of 71

8.2.9 AT#TE End timer period

Description	Command	Possible responses
Set end timer period	AT#TE=<END TIMER PERIOD>	<ul style="list-style-type: none"> • ERROR • OK
Read end timer period	AT#TE?	<END TIMER PERIOD>

This command configures the end timer duration. The end timer is started after the termination of the START timer. If the end timer expires before the DCD, DTR or data to/from the host has been detected then the μWEB Lite will enter power down state again. If DCD, DTR or data to/from the host are detected before the end timer expires, then the end timer is reset.

<END TIMER PERIOD>	Description
0 – 65535	Number of seconds to wait

8.2.10 AT#TS Start timer

Description	Command	Possible responses
Set start timer period	AT#TS= <START TIMER PERIOD>	<ul style="list-style-type: none"> • ERROR • OK
Read start timer period	AT#TS?	<START TIMER PERIOD>

This command configures the start timer duration. After an automated action, the start timer is activated. If the start timer expires before DCD, DTR or data to/from the host has been detected then the μWEB Lite will enter power down state again. If DCD, DTR or data to/from the host are detected before the start timer expires, then the end timer is activated.

<START TIMER PERIOD>	Description
0 – 65535	Number of seconds to wait

8.3 SMTP client

The SMTP client firmware build allows the host to send emails (refer to section 7.1.1). This section details the commands required to configure the SMTP client.

Before sending an email, the µWEB Lite must establish a point of presence on the Internet and connect to the SMTP server. These parameters are part of the TCP configuration (refer to section 8.5). Note: If the TCP port number is left blank, the default SMTP port number, 25 is used.

8.3.1 AT#SUS SMTP Authentication Username

Description	Command	Possible responses
Set SMTP authentication username	AT#SUS="<username>"	<ul style="list-style-type: none"> ERROR OK
Read the current setting	AT#SUS?	<username>

This command sets the username for SMTP server, which require authentication. The username must not exceed 20 characters.

8.3.2 AT#SPA SMTP Authentication Password

Description	Command	Possible responses
Set the SMTP authentication password	AT#SPA="<PASSWORD>"	<ul style="list-style-type: none"> ERROR OK
Read the current setting	AT#SPA?	<PASSWORD>

This command sets the password for SMTP server, which require authentication. The password must not exceed 20 characters.

8.3.3 AT#HOST SMTP Hostname

Description	Command	Possible responses
Set the host name	AT#HOST="<HOSTNAME>"	<ul style="list-style-type: none"> ERROR OK
Read the current setting	AT#HOST?	<HOSTNAME>

This command sets to sender's domain, this is a requirement on some SMTP servers. The maximum SMTP host name size is 40 characters.

8.3.4 AT#ATT File Attachment name

Description	Command	Possible responses
Set the attachment name	AT#ATT="<ATTACHMENT NAME>"	<ul style="list-style-type: none"> ERROR OK
Read the current attachment name	AT#ATT?	<ATTACHMENT NAME>

This command sets the attachment name used when sending data within File 1. If no attachment name is specified no attachments are sent. The maximum File Attachment Name size is 40 characters.

Filename	UWEBL_DM.DOC	Document Revision	1.7
Date of Issue	29 March 2007	Page Number	Page 38 of 71

8.3.5 AT#EML Send Email

Description	Command	Possible responses
Send email	AT#SMTP	<ul style="list-style-type: none"> • DIALING • ATD<PHONE_NUMBER> • CONNECTING • VERIFYING • LOGGING ON • PPP CONNECTED • TCP CONNECTED • SENDING EMAIL • SENT • TCP DISCONNECTED • PPP DISCONNECTED • 200 OK <p><i>*Error Responses:</i></p> <ul style="list-style-type: none"> • NO DIAL TONE • BUSY • NO ANSWER • NO CARRIER • ERROR MODEM CANT CONNECT • ERROR MODEM LOST DCD • ERROR PPP LCP NO RESPONSE • ERROR PPP LCP REJECTED • ERROR PPP LCP NO REQUEST • ERROR PPP PAP NO RESPONSE • ERROR PPP PAP REJECTED • ERROR PPP IPCP NO RESPONSE • ERROR PPP IPCP REJECTED • ERROR PPP IPCP NO REQUEST • ERROR TCP NO RESPONSE • ERROR TCP RESET • ERROR DNS NO SERVER • ERROR DNS CANT RESOLVE • SMTP HOSTNAME NOT SET • SMTP INVALID TO: • SMTP INVALID FROM:

This command allows the host to send an email to the specified email server (refer to 7.1.1). The sender, recipient, subject and body details are all stored in the email template, File 0. Several responses are issued to allow call progress to be monitored. Once "OK 200" has been received, the email has been successfully sent.

Filename	UWEBL_DM.DOC	Document Revision	1.7
Date of Issue	29 March 2007	Page Number	Page 39 of 71

8.4 FTP client

The FTP client firmware build allows the host to send and receive files from an FTP server (refer to section 7.1.2). This section details the commands required to configure the FTP client.

Before transferring files, the μWEB Lite must establish a point of presence on the Internet and connect to the FTP server. These parameters are part of the TCP configuration (refer to section 8.5). Note: If the TCP port number is left blank, the default FTP port number, 21 is used.

8.4.1 AT#FUS FTP Server Username

Description	Command	Possible responses
Set FTP authentication username	AT#FUS="<USERNAME>"	<ul style="list-style-type: none"> ERROR OK
Read the current setting	AT#FUS?	<USERNAME>

This command sets the username to gain access to the remote FTP server. The FTP username must not exceed 20 characters.

8.4.2 AT#FPA FTP Server Password

Description	Command	Possible responses
Set the FTP authentication password	AT#FPA="<PASSWORD>"	<ul style="list-style-type: none"> ERROR OK
Read the current setting	AT#FPA?	<PASSWORD>

This command sets the password to gain access to the remote FTP server. The FTP password must not exceed 20 characters.

8.4.3 AT#FPN FTP Put File Name

Description	Command	Possible responses
Set the file name when a file is sent to the FTP server.	AT#FPN ="<FILENAME>"	<ul style="list-style-type: none"> ERROR OK
Read the current setting	AT#FPF?	<FILENAME>

This command allows the user to specify the filename, which will appear on the FTP server once the contents of File1(or streamed data) has been transferred to the FTP server. The maximum put file name is 40 characters.

8.4.4 AT#FGF FTP Get File Name

Description	Command	Possible responses
Set the host name	AT#FPF ="<FILENAME>"	<ul style="list-style-type: none"> ERROR OK
Read the current setting	AT#FPF?	<FILENAME>

This command allows the user to specify the name of the file to be retrieved from the FTP server. The maximum get file name is 40 characters.

Filename	UWEBL_DM.DOC	Document Revision	1.7
Date of Issue	29 March 2007	Page Number	Page 40 of 71

8.4.5 AT#FPF FTP Put File

Description	Command	Possible responses
Put File 1 onto the FTP server.	AT#FPF	<ul style="list-style-type: none"> • DIALING • ATD08450885336 • CONNECTING • VERIFYING • LOGGING ON • PPP CONNECTED • OPENING FTP CONNECTION • LOGGING IN • ENTERING PASV MODE • SENDING FILE • CLOSING FTP CONNECTION • PPP DISCONNECTED • OK 200 <p><i>*Error Responses:</i></p> <ul style="list-style-type: none"> • NO DIAL TONE • BUSY • NO ANSWER • NO CARRIER • ERROR MODEM CANT CONNECT • ERROR MODEM LOST DCD • ERROR PPP LCP NO RESPONSE • ERROR PPP LCP REJECTED • ERROR PPP LCP NO REQUEST • ERROR PPP PAP NO RESPONSE • ERROR PPP PAP REJECTED • ERROR PPP IPCP NO RESPONSE • ERROR PPP IPCP REJECTED • ERROR PPP IPCP NO REQUEST • ERROR TCP NO RESPONSE • ERROR TCP RESET • ERROR DNS NO SERVER • ERROR DNS CANT RESOLVE • FTP PUTNAME NOT SET

This command allows the host to put the contents of File 1 onto an FTP Server in <FILENAME>. Several responses are issued to allow call progress to be monitored.

The *ENTERING PASV MODE* message indicates that a connection to the FTP server has been established. The module will then initiate the file transfer. On the µWEBBox Lite, LED2 will reflect the state of the connection i.e.LED2 will display orange when a connection is established and will clear when disconnected. If the file transfer has been successful, the following messages will appear.

OK 200

The *OK 200* message indicates the file transfer has been successful. If the FTP transfer has failed, an error message and code is sent to the host. Error numbers between 600 and 699 are communication stack errors. FTP server errors are between 400 and 599.

ERROR <error number> [<error string>]

NOTE: You must have write access permissions to write files to the FTP server

Filename	UWEBL_DM.DOC	Document Revision	1.7
Date of Issue	29 March 2007	Page Number	Page 41 of 71

8.4.6 AT#FGF FTP Get File

Description	Command	Possible responses
Get File 1 from the FTP server.	AT#FGF	<ul style="list-style-type: none"> • DIALING • ATD08450885336 • CONNECTING • VERIFYING • LOGGING ON • PPP CONNECTED • OPENING FTP CONNECTION • LOGGING IN • ENTERING PASV MODE • RECEIVING FILE • CLOSING FTP CONNECTION • PPP DISCONNECTED • OK 200 <p><i>*Error Responses:</i></p> <ul style="list-style-type: none"> • NO DIAL TONE • BUSY • NO ANSWER • NO CARRIER • ERROR MODEM CANT CONNECT • ERROR MODEM LOST DCD • ERROR PPP LCP NO RESPONSE • ERROR PPP LCP REJECTED • ERROR PPP LCP NO REQUEST • ERROR PPP PAP NO RESPONSE • ERROR PPP PAP REJECTED • ERROR PPP IPCP NO RESPONSE • ERROR PPP IPCP REJECTED • ERROR PPP IPCP NO REQUEST • ERROR TCP NO RESPONSE • ERROR TCP RESET • ERROR DNS NO SERVER • ERROR DNS CANT RESOLVE • FTP GETNAME NOT SET

This command allows the host to get the contents of File 1 from an FTP Server in <FILENAME>. Several responses are issued to allow call progress to be monitored. Once "OK 200" has been received, the file has been successfully retrieved.

The *ENTERING PASV MODE* message indicates that a connection to the FTP server has been established. The µWEB Lite will then initiate the file transfer. On the µWEBBox Lite, LED2 will reflect the state of the connection i.e.LED2 will display orange when a connection is established and will clear when disconnected. If the file transfer has been successful, the following messages will appear.

OK 200

The *OK 200* message indicates the file transfer has been successful. If the FTP transfer has failed, an error message and code is sent to the host. Error numbers between 600 and 699 are communication stack errors. FTP server errors are between 400 and 599.

ERROR <error number> [<error string>]

Filename	UWEBL_DM.DOC	Document Revision	1.7
Date of Issue	29 March 2007	Page Number	Page 42 of 71

8.4.7 AT#FMF FTP File Move

Description	Command	Possible responses
Get File 1 from the FTP server and delete the original file	AT#FGF	<ul style="list-style-type: none"> • DIALING • ATD08450885336 • CONNECTING • VERIFYING • LOGGING ON • PPP CONNECTED • OPENING FTP CONNECTION • LOGGING IN • ENTERING PASV MODE • RECEIVING FILE • CLOSING FTP CONNECTION • PPP DISCONNECTED • OK 200 <p><i>*Error Responses:</i></p> <ul style="list-style-type: none"> • NO DIAL TONE • BUSY • NO ANSWER • NO CARRIER • ERROR MODEM CANT CONNECT • ERROR MODEM LOST DCD • ERROR PPP LCP NO RESPONSE • ERROR PPP LCP REJECTED • ERROR PPP LCP NO REQUEST • ERROR PPP PAP NO RESPONSE • ERROR PPP PAP REJECTED • ERROR PPP IPCP NO RESPONSE • ERROR PPP IPCP REJECTED • ERROR PPP IPCP NO REQUEST • ERROR TCP NO RESPONSE • ERROR TCP RESET • ERROR DNS NO SERVER • ERROR DNS CANT RESOLVE • FTP GETNAME NOT SET

This command allows the host to get the contents of File 1 from an FTP Server in <FILENAME>. Once the file has been successfully retrieved the original file on the FTP server is deleted. Several responses are issued to allow call progress to be monitored. Once "OK 200" has been received, the file has been successfully retrieved.

The *ENTERING PASV MODE* message indicates that a connection to the FTP server has been established. The µWEB Lite will then initiate the file transfer. On the µWEBBox Lite, LED2 will reflect the state of the connection i.e.LED2 will display orange when a connection is established and will clear when disconnected. If the file transfer has been successful, the following messages will appear.

OK 200

The *OK 200* message indicates the file transfer has been successful. If the FTP transfer has failed, an error message and code is sent to the host. Error numbers between 600 and 699 are communication stack errors. FTP server errors are between 400 and 599.

ERROR <error number> [<error string>]

Filename	UWEBL_DM.DOC	Document Revision	1.7
Date of Issue	29 March 2007	Page Number	Page 43 of 71

8.4.8 AT#FPS FTP Put Stream

Description	Command	Possible responses
Put streamed data onto the FTP server.	AT#FPF	<ul style="list-style-type: none"> • DIALING • ATD08450885336 • CONNECTING • VERIFYING • LOGGING ON • PPP CONNECTED • OPENING FTP CONNECTION • LOGGING IN • ENTERING PASV MODE • SEND DATA - END WITH "+++" OR TOGGLE RTS • CLOSING FTP CONNECTION • PPP DISCONNECTED • OK 200 <p><i>*Error Responses:</i></p> <ul style="list-style-type: none"> • NO DIAL TONE • BUSY • NO ANSWER • NO CARRIER • ERROR MODEM CANT CONNECT • ERROR MODEM LOST DCD • ERROR PPP LCP NO RESPONSE • ERROR PPP LCP REJECTED • ERROR PPP LCP NO REQUEST • ERROR PPP PAP NO RESPONSE • ERROR PPP PAP REJECTED • ERROR PPP IPCP NO RESPONSE • ERROR PPP IPCP REJECTED • ERROR PPP IPCP NO REQUEST • ERROR TCP NO RESPONSE • ERROR TCP RESET • ERROR DNS NO SERVER • ERROR DNS CANT RESOLVE • FTP PUTNAME NOT SET

This command allows the host to stream data onto an FTP Server in <FILENAME>. Several responses are issued to allow call progress to be monitored.

The *ENTERING PASV MODE* message indicates that a connection to the FTP server has been established. The µWEB Lite will then prompt the host for file data. The host streams data to the µWEB Lite after the SEND DATA line message is received (DCD active) and ends the stream by sending +++ preceded by a pause of at least one second. The DCD line can be used to determine when to start streaming from the host to the module. On the µWEB Lite, LED2 will reflect the state of the connection i.e.LED2 will display orange when a connection is established and will clear when disconnected. If the file transfer has been successful, the following messages will appear.

OK 200

The *OK 200* message indicates the file transfer has been successful. If the FTP transfer has failed, an error message and code is sent to the host. Error numbers between 600 and 699 are communication stack errors. FTP server errors are between 400 and 599.

ERROR <error number> [<error string>]

NOTE: You must have write access permissions to write files to the FTP server

Filename	UWEBL_DM.DOC	Document Revision	1.7
Date of Issue	29 March 2007	Page Number	Page 44 of 71

8.4.9 AT#FGS FTP Get Stream

Description	Command	Possible responses
Stream data from a file on an FTP Server	AT#FGF	<ul style="list-style-type: none"> • DIALING • ATD08450885336 • CONNECTING • VERIFYING • LOGGING ON • PPP CONNECTED • OPENING FTP CONNECTION • LOGGING IN • ENTERING PASV MODE • RECEIVING FILE • CLOSING FTP CONNECTION • PPP DISCONNECTED • OK 200 <p><i>*Error Responses:</i></p> <ul style="list-style-type: none"> • NO DIAL TONE • BUSY • NO ANSWER • NO CARRIER • ERROR MODEM CANT CONNECT • ERROR MODEM LOST DCD • ERROR PPP LCP NO RESPONSE • ERROR PPP LCP REJECTED • ERROR PPP LCP NO REQUEST • ERROR PPP PAP NO RESPONSE • ERROR PPP PAP REJECTED • ERROR PPP IPCP NO RESPONSE • ERROR PPP IPCP REJECTED • ERROR PPP IPCP NO REQUEST • ERROR TCP NO RESPONSE • ERROR TCP RESET • ERROR DNS NO SERVER • ERROR DNS CANT RESOLVE • FTP GETNAME NOT SET

This command allows the host to stream data from a file on the FTP Server. Several responses are issued to allow call progress to be monitored. Once "OK 200" has been received, the file has been successfully retrieved.

The *ENTERING PASV MODE* message indicates that a connection to the FTP server has been established. The *RECEIVING FILE* message will precede the file data. *CLOSING FTP CONNECTION* indicates that file data has finished being streamed. The DCD line can be used to frame the received data. DCD will become active (low for TTL) when the µWEB Lite is streaming file data. DCD will become inactive when the µWEB Lite has stopped streaming data. There is a half second pause between start / stop of DCD signalling and the data starting / stopping. On the µWEBBox Lite, LED2 will reflect the state of the connection i.e. LED2 will display orange when a connection is established and will clear when disconnected. If the file transfer has been successful, the following messages will appear.

OK 200

The *OK 200* message indicates the file transfer has been successful. If the FTP transfer has failed, an error message and code is sent to the host. Error numbers between 600 and 699 are communication stack errors. FTP server errors are between 400 and 599.

ERROR <error number> [<error string>]

Filename	UWEBL_DM.DOC	Document Revision	1.7
Date of Issue	29 March 2007	Page Number	Page 45 of 71

8.4.10 AT#FMS FTP Move Stream

Description	Command	Possible responses
Stream data from a file on an FTP Server and delete the original file	AT#FMS	<ul style="list-style-type: none"> • DIALING • ATD08450885336 • CONNECTING • VERIFYING • LOGGING ON • PPP CONNECTED • OPENING FTP CONNECTION • LOGGING IN • ENTERING PASV MODE • RECEIVING FILE • CLOSING FTP CONNECTION • PPP DISCONNECTED • OK 200 <p><i>*Error Responses:</i></p> <ul style="list-style-type: none"> • NO DIAL TONE • BUSY • NO ANSWER • NO CARRIER • ERROR MODEM CANT CONNECT • ERROR MODEM LOST DCD • ERROR PPP LCP NO RESPONSE • ERROR PPP LCP REJECTED • ERROR PPP LCP NO REQUEST • ERROR PPP PAP NO RESPONSE • ERROR PPP PAP REJECTED • ERROR PPP IPCP NO RESPONSE • ERROR PPP IPCP REJECTED • ERROR PPP IPCP NO REQUEST • ERROR TCP NO RESPONSE • ERROR TCP RESET • ERROR DNS NO SERVER • ERROR DNS CANT RESOLVE • FTP GETNAME NOT SET

This command allows the host to stream data from a file on the FTP Server. Once the file contents have been successfully retrieved, the original file on the FTP server is deleted. Several responses are issued to allow call progress to be monitored. Once "OK 200" has been received, the file has been successfully retrieved.

The *ENTERING PASV MODE* message indicates that a connection to the FTP server has been established. The μWEB Lite will then initiate the file transfer. On the μWEBBox Lite, LED2 will reflect the state of the connection i.e.LED2 will display orange when a connection is established and will clear when disconnected. If the file transfer has been successful, the following messages will appear.

OK 200

The *OK 200* message indicates the file transfer has been successful. If the FTP transfer has failed, an error message and code is sent to the host. Error numbers between 600 and 699 are communication stack errors. FTP server errors are between 400 and 599.

ERROR <error number> [<error string>]

Filename	UWEBL_DM.DOC	Document Revision	1.7
Date of Issue	29 March 2007	Page Number	Page 46 of 71

8.5 TCP socket client

The μWEB Lite provides an embedded TCP/IP stack. This allows the host (referred to as the client) to connect to a TCP socket (referred to as the server). The TCP client can be initiated by either the host (refer to section 8.5.5) or automated mode (refer to section 8.2.1).

Before a TCP connection can be created, the μWEB Lite must establish a point of presence on the Internet. This point of presence is provided by the Internet Service Provider (ISP). The following μWEB Lite commands are used to configure the ISP details. The ISP phone number is stored in AT#D0 (refer to section 8.9.3).

8.5.1 AT#PUS PPP Username

Description	Command	Possible responses
Set the PPP username	AT#PUS=<USERNAME>	<ul style="list-style-type: none"> • ERROR • OK
Read the current setting	AT#PUS?	<USERNAME>

This command is used to configure the PPP username. The user's ISP should provide a valid username and password when an account has been created. The PPP username string must be within double quotes and no greater than 20 characters long.

8.5.2 AT#PPA PPP Password

Description	Command	Possible responses
Set the PPP password	AT#PPA=<PASSWORD>	<ul style="list-style-type: none"> • ERROR • OK
Read the current setting	AT#PPA?	<PASSWORD>

This command is used to configure the PPP password. The user's ISP should provide a valid username and password when an account has been created. The PPP password string must be within double quotes and no greater than 20 characters long.

8.5.3 AT#RIP Remote IP address

Description	Command	Possible responses
Set the remote IP address	AT#RIP=<ADDRS>	<ul style="list-style-type: none"> • ERROR • OK
Read the current setting	AT#RIP?	<ADDRS>

This command sets the address of TCP server, this address can be specified as either an IP address (*nnn.nnn.nnn.nnn*) or a domain address up to 40 characters long.

8.5.4 AT#RPO Remote Port number

Description	Command	Possible responses
Set the remote port number	AT#RPO=<PORT NUMBER>	<ul style="list-style-type: none"> • ERROR • OK
Read the current setting	AT#RPO?	<PORT NUMBER>

This command sets the port number of the TCP server.

8.5.5 AT#TCP Establish a TCP connection

Description	Command	Possible responses
Establish a TCP connection	AT#TCP	<ul style="list-style-type: none"> • ERROR • DIALING • <PHONE_NUMBER> • CONNECTING • VERIFYING • LOGGING ON • PPP CONNECTED • TCP CONNECTED • NO DIAL TONE • BUSY • NO ANSWER • NO CARRIER • DISCONNECTING • OK

This command establishes a TCP connection. Several responses are issued to allow call progress to be monitored. Once "TCP CONNECTED" has been received, the TCP socket is open. DCD is also asserted at this time. The connection may be closed either by the far end closing the socket, deactivating DTR or by issuing the TIES sequence (no data for a period greater than a second, followed by "+++"). DCD is deactivated once the socket is closed.

Filename	UWEBL_DM.DOC	Document Revision	1.7
Date of Issue	29 March 2007	Page Number	Page 48 of 71

8.6 Filing System

The μWEB Lite has an external EEPROM used to provide two files: File0 and File1. The function of these files varies with each Firmware build. These section details the command associated with the filing system.

8.6.1 AT#RD Read File

Description	Command	Possible responses
Read file <FILE>	AT#RD <FILE>	<ul style="list-style-type: none"> ERROR OK

<FILE>	Description
0	File 0
1	File 1

The command streams the contents of the file specified to the host.

8.6.2 AT#WR Write Data to File

Description	Command	Possible responses
Write <DATA> to file <FILE>	AT#WR<FILE>"<DATA>"	<ul style="list-style-type: none"> ERROR OK

<FILE>	Description
0	File 0
1	File 1

As with most command lines, there are certain characters that cannot be entered. To write these values into a file they must be escaped on the command line. Any byte value can be sent using the hex escape sequence \x followed by a 2 digit hexadecimal value representing the byte value. All other characters can be sent directly on the command line without any modification. The command line has a maximum limit of 160 characters. This is inclusive of the command and any escape characters.

8.6.3 AT#WRLN Write Data to File and Append

Description	Command	Possible responses
Write <DATA> to file <FILE>	AT#WR<FILE>"<DATA>"	<ul style="list-style-type: none"> ERROR OK

<FILE>	Description
0	File 0
1	File 1

This command operates similar to AT#WR, with the automatic appending of carriage return and line feed at the end of <DATA>.

Filename	UWEBL_DM.DOC	Document Revision	1.7
Date of Issue	29 March 2007	Page Number	Page 49 of 71

8.6.4 AT#DEL Delete File

Description	Command	Possible responses
Delete file <FILE>	AT#DEL <FILE>	<ul style="list-style-type: none"> • ERROR • OK

<FILE>	Description
0	File 0
1	File 1

The command deletes the contents of the file specified.

8.6.5 AT#DIR List Files

Description	Command	Possible responses
List File usage	AT#DIR	<ul style="list-style-type: none"> • ERROR • OK

The command lists the current file usage:

```

at#dir
File   Len   Max Size
=====
0      83     8192
1      27     55276

OK
    
```

8.7 I/O and ADC monitoring

The μWEB Lite provides 8 digital I/O lines and 4 10-bit ADC channels. The μWEBBox Lite provides 4 digital I/O lines (2 input, 2 output) and 3 10-bit ADC channels. The I/O and ADCs provide remote monitoring and can be used to invoke an automated action (refer to section 8.2.1). The associated I/O and ADC commands are detailed below.

8.7.1 AT#IOC IO Direction Control

Description	Command	Possible responses
Set the IO direction control	AT#IOC=<IO DIR>*	<ul style="list-style-type: none"> ERROR OK
Read the IO direction control	AT#IOC?	<IO DIR>

This command is used to configure the digital I/O direction. The μWEB Lite provides 8 digital I/O lines on CON2, each can be individually configured as either an input or output.

μWEB Lite I/O (CON2)	<IO DIR> bit
Pin3, I/O0	0
Pin4, I/O1	1
Pin5, I/O2	2
Pin6, I/O3	3
Pin7, I/O4	4
Pin8, I/O5	5
Pin9, I/O6	6
Pin10, I/O7	7

Where:

<IO DIR> bit value	I/O direction
1	Input
0	Output

The value <IO DIR> is entered and displayed in hexadecimal format.

*Note this feature is not supported on the μWEBBox Lite, since the I/O lines and associated direction are fixed.

8.7.2 AT#IOW IO Port Write

Description	Command	Possible responses
Write to IO Port	AT#IOW=<IO DATA>	<ul style="list-style-type: none"> • ERROR • OK

This command is used to write data to the I/O lines. The value <IO DATA> is entered in hexadecimal format.

IO DATA (bit)*	μWEB Lite I/O line	CON2 Pin
0	0	3
1	1	4
2	2	5
3	3	6
4	4	7
5	5	8
6	6	9
7	7	10

IO DATA (bit)	μWEBBox Lite Output line	CON2 Pin
0	0	10
1	1	12
2	-	-
3	-	-
4	-	-
5	-	-
6	-	-
7	-	-

*Note only when configured as an output, refer to section 8.7.1.

eg – to set outputs 0, 2, 3 and 5 of the μWEB Lite module to 1 the command would be:

at#iow=4D

8.7.3 AT#IOR IO Port Read

Description	Command	Possible responses
Read IO port	AT#IOR?	<IO DATA>

This command is used to read data from the I/O lines. The value <IO DATA> is displayed in hexadecimal format.

IO DATA (bit)*	μWEB Lite I/O line	CON2 Pin
0	0	3
1	1	4
2	2	5
3	3	6
4	4	7
5	5	8
6	6	9
7	7	10

IO DATA (bit)	μWEBBox Lite Input line	CON2 pin
0	0	3
1	1	4
2	-	-
3	-	-
4	-	-
5	-	-
6	-	-
7	-	-

*Note only when configured as an input, refer to section 8.7.1.

Filename	UWEBL_DM.DOC	Document Revision	1.7
Date of Issue	29 March 2007	Page Number	Page 52 of 71

8.7.4 AT#IOA IO Port AND

Description	Command	Possible responses
Logical AND <IO DATA> with IO Port	AT#IOA=<IO DATA>	<ul style="list-style-type: none"> • ERROR • OK

This command performs a logical AND of <IO DATA> with the current I/O Port value. The value <IO DATA> is entered in hexadecimal format.

μWEB Lite		
IO DATA (bit)*	I/O line	CON2 Pin
0	0	3
1	1	4
2	2	5
3	3	6
4	4	7
5	5	8
6	6	9
7	7	10

μWEBBox Lite		
IO DATA (bit)	Output line	CON2 Pin
0	0	10
1	1	12
2	-	-
3	-	-
4	-	-
5	-	-
6	-	-
7	-	-

*Note only when configured as an output, refer to section 8.7.1.

8.7.5 AT#IOO IO Port OR

Description	Command	Possible responses
Logical OR <IO DATA> with IO Port	AT#IOA=<IO DATA>	<ul style="list-style-type: none"> • ERROR • OK

This command performs a logical OR of <IO DATA> with the current I/O Port value. The value <IO DATA> is entered in hexadecimal format.

μWEB Lite		
IO DATA (bit)*	I/O line	CON2 Pin
0	0	3
1	1	4
2	2	5
3	3	6
4	4	7
5	5	8
6	6	9
7	7	10

μWEBBox Lite		
IO DATA (bit)	Output line	CON2 Pin
0	0	10
1	1	12
2	-	-
3	-	-
4	-	-
5	-	-
6	-	-
7	-	-

*Note only when configured as an output, refer to section 8.7.1.

8.7.6 AT#ADR Read ADC channel

Description	Command	Possible responses
Read ADC channel	AT#ADR<CHANNEL>?	<ul style="list-style-type: none"> • <ADC VALUE> • OK

This command is used to read one of the 4 10-bit binary sigma-delta ADC channels onboard the μWEB Lite. The value <ADC VALUE> is displayed in hexadecimal format. The ADCs can also be used as a wakeup source when used in conjunction with the ADC thresholds (refer to section 8.2.7 & 8.2.8) and the wake up source (refer to section 8.2.2). The Configuration Bitmap Register is used to select which ADC channels are use as a wakeup source (refer to section 8.9.1).

<CHANNEL>	Description
0	ADC channel 0
1	ADC channel 1
2	ADC channel 2
3	ADC channel 3*

*Note not supported on the μWEBox Lite.

8.8 GPS

Both the μWEB Lite and μWEBBox Lite can provide global positioning information. The μWEB Lite must be used in conjunction with the OEM-GPS unit to provide positioning information. The μWEBBox Lite has an optional GPS unit fit, which is used to provide positioning information. The commands to support global positioning are detailed below.

8.8.1 AT#GPC GPS Unit Control

Description	Command	Possible responses
Set GPS power control	AT#GPC=<ENABLE>	<ul style="list-style-type: none"> OK ERROR
Read GPS power control	AT#GPC?	<ul style="list-style-type: none"> <ENABLE> OK

Allows the GPS unit to be turned on/off from the AT command line (if installed).

<ENABLE>	Description
0	Turn off GPS Unit
1	Turn on GPS Unit

8.8.2 AT#GPL GPS location (GPRMC string)

Description	Command	Possible responses
Read GPS power control	AT#GPL?	<ul style="list-style-type: none"> <GPRMC string> OK

This command returns the GPRMC string (recommended minimum specific GPS/transit data) from the GPS unit (if installed) to the DTE.

8.8.3 AT#GPT GPS timeout

Description	Command	Possible responses
Set GPS timeout	AT#GPT=<TIMER VALUE>	<ul style="list-style-type: none"> ERROR OK
Read GPS timeout	AT#GPT?	<ul style="list-style-type: none"> <TIMER VALUE> OK

This command is used to configure the GPS timeout used when sending an automated SMS with GPS string. The automated SMS message is sent when either the GPS timer expires or a GPS fix is obtained.

<TIME VALUE>	Description
0 – 65535	GPS timeout in seconds

Filename	UWEBL_DM.DOC	Document Revision	1.7
Date of Issue	29 March 2007	Page Number	Page 55 of 71

8.9 Configuration

The μWEB Lite has a number of configuration commands, which are used to configure

- Additional automated parameters
- Additional wakeup parameters
- Operating parameters

8.9.1 AT#CFG Configuration Bitmap Register

Description	Command	Possible responses
Set configuration bitmap register	AT#CFG=<BITMAP>	<ul style="list-style-type: none"> • ERROR • OK
Read configuration bitmap register	AT#CFG?	<BITMAP> OK

This command is used to set the configuration bitmap register. This register is used to configure the following options:

Bit position	Option	Description
0	Mode complete response	<p>This option is used to determine whether the success of the automated action is reported to the host after completion.</p> <p>OK Automated mode successfully executed ERROR Automated mode failed</p>
1	Echo control	<p>This option is used by the external driver to indicate the echo state on the GR47/48. It is highly recommended that the user reflects the echo state of the GR47/48 (ATE) with the Echo control. For example if the GR47/48's echo is enabled (ATE1), then the Echo control bit should also be set.</p>
2	Retain validated SMS wakeup Messages	<p>This option will determine if SMS wakeup sources are deleted when they have been successfully validated against the username and password. This prevents the SMS storage area from filling up.</p>
3	Append I/O and ADC	<p>This option determines whether the following I/O and ADC information is appended to an automated SMS:</p> <ul style="list-style-type: none"> • Current I/O states (IO0-7) in hexadecimal format • Current ADC value with upper and lower threshold values for ADC0-3.
4	Check ADC0 thresholds	<p>If the ADC threshold wakeup source is selected this option will determine if ADC0 thresholds are checked.</p>
5	Check ADC1 thresholds	<p>If the ADC threshold wakeup source is selected this option will determine if ADC1 thresholds are checked.</p>
6	Check ADC2 thresholds	<p>If the ADC threshold wakeup source is selected this option will determine if ADC2 thresholds are checked.</p>
7	Check ADC3 thresholds*	<p>If the ADC threshold wakeup source is selected this option will determine if ADC3 thresholds are checked.</p>

*Note not supported on the μWEBBox Lite.

Filename	UWEBL_DM.DOC	Document Revision	1.7
Date of Issue	29 March 2007	Page Number	Page 56 of 71

8.9.2 AT#BR Baudrate Control

Description	Command	Possible responses
Set baudrate	AT#BR=<BAUDRATE>	<ul style="list-style-type: none"> • ERROR • OK
Read baudrate	AT#BR?	<ul style="list-style-type: none"> • <BAUDRATE> • OK

This command specifies the data rate at which the DCE will accept commands. This command will configure both the external controller and GR47/48 data rates. The specified rate takes effect immediately. It is recommended this command be used rather than the GR47/48 at+ipr commands.

<BAUDRATE>	Actual Baudrate
0	1200bps
1	2400bps
2	4800bps
3	9600bps
4	19200bps
5	38400bps
6	57600bps
7	115200bps

8.9.3 AT#D Autodial number

Description	Command	Possible responses
Set autodial number	AT#D<AUTODIAL ID>=<DIAL NUMBER>	<ul style="list-style-type: none"> • ERROR • OK
Read the current setting	AT#D<AUTODIAL ID>?	<ul style="list-style-type: none"> • <DIAL NUMBER> • OK

This command sets the specified autodial number, which is used when the mode of operation is configured to automatically initiate a remote connection or SMS response. There are two autodial numbers support (AT#D0, AT#D1)

<AUTODIAL ID>	Description
Digit	Autodial number identifier (0-1)

<DIAL_NUMBER>	Description
String type	Number to be dialled

With both the SMTP and FTP client Firmware builds, the AT#D0 command is used to store the ISP telephone number.

If both autodial numbers are not configured and a remote unit triggers a wakeup source (via RING or SMS), then the remote number is used instead (if available). Autodial numbers strings must be within double quotes e.g. AT#D0="+447803123456".

Filename	UWEBL_DM.DOC	Document Revision	1.7
Date of Issue	29 March 2007	Page Number	Page 57 of 71

8.9.4 AT#F Restore default factory configuration

Description	Command	Possible responses
Restore COMTECH specific parameters to default factory configuration	AT#F	<ul style="list-style-type: none"> OK

This command set all AT# parameters to default values.

8.9.5 AT#G Control GR47/48 ENGINE

Description	Command	Possible responses
Set GR47/48 engine power control	AT#G=<ENABLE>	<ul style="list-style-type: none"> OK ERROR
Read GR47/48 engine power control	AT#G?	<ul style="list-style-type: none"> <ENABLE> OK

Allows the GR47/48 to be turned on/off from the AT command line.

<ENABLE>	Description
0	Turn off the GR47/48 engine
1	Turn on the GR47/48 engine

8.9.6 AT#INI Initialisation String

Description	Command	Possible responses
Set GR47/48 initialisation string	AT#INIT=<INIT STRING>	<ul style="list-style-type: none"> OK ERROR
Read GR47/48 initialisation string	AT#INIT?	<ul style="list-style-type: none"> <INIT STRING> OK

This command allows the user to create an initialise string for the GR47/48. The initialisation string can be up to 150 characters. The initialisation string can contain numerous sub-initialisation strings, each sent individually to the GR47/48 ENGINE. The sub-initialisation strings are identified by the start and end delimiters '[' and ']' and do not require the initial 'AT'. The initialisation string must be within double quotes, all double quotes within delimiters are ignored.

As an example if the user wanted to configure the GR47/48 to send text based SMS message within the initialisation string, the following AT#INI command could be used:

```
AT#INI="[+CPMS="ME",ME,"ME"]+[CNMI=3,1,0,0,0][+CSDH=1][+CSMP=17,167,0,0][+CMGF=1]"<CR>
```

Filename	UWEBL_DM.DOC	Document Revision	1.7
Date of Issue	29 March 2007	Page Number	Page 58 of 71

8.9.7 AT#MRI Modem Reset Interval

Description	Command	Possible responses
Set GSM/GPRS modem receiver reset interval	AT#MRI=<INTERVAL>	<ul style="list-style-type: none"> ERROR OK

This command causes the μWEB Lite to periodically deregister and power cycle the GSM/GPRS modem receiver, effectively resetting the modem receiver. The <interval> is time interval between resetting the receiver in minutes (0-65535). A value of zero will disable this feature. The μWEB Lite will add an additional 10 minutes random offset to the specified time interval to reduce the likelihood of coinciding with any scheduled network calls. If the time interval lapses during a network call, the receiver reset will only occur once the call is complete. During the reset any AT commands other than AT# commands issued to the μWEB Lite will return ERROR. **Note this command will automatically store the current configuration and is only available with firmware 4.15 or higher.**

8.9.8 AT#MRST Modem Reset

Description	Command	Possible responses
Reset GSM/GPRS modem receiver	AT#MRST	<ul style="list-style-type: none"> ERROR OK

This command causes the μWEB Lite to deregister and power cycle the GSM/GPRS modem receiver, effectively resetting the modem receiver. The μWEB Lite returns OK once the reset is complete. **Note this command is only available with firmware 4.15 or higher**

8.9.9 AT#PAU Pause

Description	Command	Possible responses
Pause <DELAY> seconds	AT#PAU=<DELAY>	<ul style="list-style-type: none"> ERROR OK

This command causes a pause on the command line for <DELAY> seconds. The pause command is useful for generating pulses on the I/O lines when using the command line via the SMS.

8.9.10 AT#RSC RS232 Mode

Description	Command	Possible responses
Set the RS232 Mode	AT#RSC=<RS232 MODE>	<ul style="list-style-type: none"> ERROR OK
Read the current RS232 mode	AT#RSC?	<RS232 MODE>

To reduce the current consumption on the μWEB Lite modules which provide an RS232 interface, three different RS232 operating modes are provided.

<RS232 MODE>	Description
0	The RS232 device is on continuously
1	The RS232 device powers down after if none the lines on the RS232 interface change after 30 seconds.
2	RS232 powers down when waiting for a wakeup source

Filename	UWEBL_DM.DOC	Document Revision	1.7
Date of Issue	29 March 2007	Page Number	Page 59 of 71

8.9.11 AT#RTC Real Time Clock Control

Description	Command	Possible responses
Set the RTC	AT#RTC= "<HH:MM:SS DOW DD MN YY>"	<ul style="list-style-type: none"> • ERROR • OK
Read the current RTC	AT#RTC?	<HH:MM:SS DOW DD MN YY>

Where:

HH	Hour (0-23)
MM	Minute (0-59)
SS	Seconds (0-59)
DOW	The day of the week: 0 – Sunday 1 – Monday 2 – Tuesday 3 – Wednesday 4 – Thursday 5 – Friday 6 – Saturday
DD	Day of the month (1-31)
MN	Month of the year (1-12)
YY	Year (00-99)

This command is used to both set and query the real time clock. If the real time clock battery and external power are removed, the real time clock will not run until set. The real time clock string must be within double quotes.

8.9.12 AT#SLP Sleep Mode Enable

Description	Command	Possible responses
Set wakeup source	AT#WAK	<ul style="list-style-type: none"> • ERROR • OK
Enable sleep mode	AT#SLP	

This command is used to put the module into sleep mode. Please ensure that the appropriate wakeup sources are configured via AT#WAK before entering sleep mode (refer to section 8.2.2).

8.9.13 AT#SMS Static SMS Message

Description	Command	Possible responses
Set static SMS message	AT#SMS="<SMS MESSAGE>"	<ul style="list-style-type: none"> • ERROR • OK
Read static SMS message	AT#SMS?	<SMS MESSAGE>

This command configures the content of the automated SMS message. The static SMS message must be within double quotes and must not exceed 160 characters.

8.9.14 AT#STO Store Configuration

Description	Command	Possible responses
Store current configuration	AT#STO	<ul style="list-style-type: none"> • OK

This command stores the current GSM/GPRS module and extended configuration modes to non-volatile memory.

8.9.15 AT#Z Reset device

Description	Command	Possible responses
Reset device	AT#Z	None

This command power cycles the μWEB Lite.

8.10 Information

The μWEB Lite provides additional commands to highlight firmware revision, identification and extended commands support.

8.10.1 AT#HELP List available AT# commands

Description	Command	Possible responses
List available AT# commands	AT#HELP	<ul style="list-style-type: none"> OK

This command lists the available AT# commands.

8.10.2 AT#I Module identity

Description	Command	Possible responses
Read module Identity	AT#I	<ul style="list-style-type: none"> <MODULE IDENTITY>

8.10.3 AT#V Firmware Version number

Description	Command	Possible responses
Read firmware version number	AT#V?	<VERSION>

This command displays the current firmware version number. This number can be used to identify which extended COMTECH features are supported.

Filename	UWEBL_DM.DOC	Document Revision	1.7
Date of Issue	29 March 2007	Page Number	Page 62 of 71

9 Remote Command Line Access

The μWEB Lite GSM/GPRS product family provide remote access to all the Comtech extended AT# commands. This feature allows the user to configure, monitor and even update the firmware remotely.

To access this feature the μWEB Lite or associated host must answer an incoming call. Both the μWEB Lite can be configured to auto answer incoming calls by setting S register 0 to a value other than zero.

To access the remote command line, dial the μWEB Lite and wait for the standard connected message. Once a data call has been established, the user can gain access to the remote command line by using the escape sequence “---”, followed by a one second pause. After the unit has received the escape sequence, the user should receive the ‘OK’ response, indicating the remote command line access is active.

The user can return to the normal data mode from the remote command line by using the AT#O command. The unit will respond with a ‘CONNECT’ message, indicating the unit has returned to data mode.

The example below shows the typical response when accessing the remote command line, the responses from the μWEB Lite are in RED.

```

ATD0777111222<CR>      < Establish connection to μWEB Lite
CONNECT 9600            < Data connection established
---                     < Send remote escape sequence
OK                      < Remote command line response
AT#VER<CR>             < Send remote command
AT#VER                 < Remote echo
2.03                   < Remote command response

OK
AT#O<CR>               < Return to data connection
AT#O                   < Remote echo
CONNECT                < Data connection response
    
```

Filename	UWEBL_DM.DOC	Document Revision	1.7
Date of Issue	29 March 2007	Page Number	Page 63 of 71

10 Updating Firmware

Both the µWEB Lite provide the ability to update the firmware on the external controller/driver both locally and remotely. Firmware updates will be available from the Comtech website (www.comtech.uk.com).

A small bootloader program on the external controller performs the firmware updates. The AT#UPL command will activate the bootloader. Once the bootloader is active it is impossible to return to the µWEB Lite application until a valid firmware image has been downloaded to the board.

10.1 Local Firmware Update

Issue the AT#UPL command to initiate a firmware update. There is a small delay before the 'OK' response is received, indicating the bootloader has been invoked.

Before performing any firmware update either locally or remotely, the bootloader will power cycle the GSM/GPRS receiver. Once the receiver is on, indicated by either a solid or flashing green led, the boot loader is ready for a new image. The default baudrate for the bootloader is 115200bps. To indicate the image update is local, press the escape key, the following prompt should appear:

```
BOOTLOADER V1.0
Start xmodem
```

Send the image file to the unit using Xmodem. Once the image download is complete, the application will boot immediately.

Note that local firmware updates are supported by the µWEB Lite Configuration Tool. Please refer to the [µWEB Lite Configuration Tool Manual](#) for details.

10.2 Remote Firmware Update

Access the command line remotely (refer to section 9) and issue the AT#UPL command to initiate a firmware update. There is a small delay before the 'OK' response is received, indicating the bootloader has been invoked.

Before performing any firmware update either locally or remotely, the bootloader will power cycle the GSM/GPRS receiver. Once this occurs, the remote command line connection is terminated and the bootloader is ready for an incoming call. **The bootloader validates an incoming call using two rings, therefore S register 0 must be set to answer on 3 rings or higher.**

Once a connection has been re-established the following prompt will appear:

```
BOOTLOADER V1.0
Start xmodem
```

Send the firmware file (*.upl) to the unit using Xmodem. Once the image download is complete, the application will boot immediately and the remote connection terminated.

Filename	UWEBL_DM.DOC	Document Revision	1.7
Date of Issue	29 March 2007	Page Number	Page 64 of 71

11 ELECTRICAL CHARACTERISTICS

11.1 DC Electrical Characteristics

TA = -20 to 55 (75C) degrees Centigrade

Parameter	Conditions	Min	Typ	Max	Units
Vcc (internal)		3	3.3	3.6	Volts
Icc					
Icpk	Power on transient (approx 10ms)	-	1.5	-	A
Icc	Idle	-	39	-	mA
Iccdm (ave)	Transmit/ Operational	-	-	500	mA
Icdm (pk)	Transmit/ Operational	-	-	2A	mA
Icc2 (Reset)		TBA	TBA	TBA	mA
I/O Type 1					
Vil1		-0.3		1.08	V
Vih1		2.1	-	5.5	V
Voh1	-2mA	2.7	-	-	V
Vol1	2mA	-	-	0.4	V
I/O Type 2					
Vil2		-0.3		1.08	V
Vih2		2.1	TBA	5.5	V
Voh2	-2mA	2.1	-	-	V
Vol2	2mA	-	-	0.94	V
I/O Type 3 (ADC inputs)					
Resolution	Vref=3.3V	10	-	-	bits
Differential non-linearity		-0.25	-	+0.25	lsb
Integral non-linearity	Vref=3.3V	-2	-	+2	lsb
DC offset error		-50		+25	mV
Single-Shot Conversion Period		-	5129	-	Clock cycles
Continuous Conversion Period		-	256	-	Clock cycles
Analogue Source Impedance	Recommended	-	-	150	Ohm
Input Impedance		-	150	-	kOhm
I/O Type 4					
Vil4	-	0	-	0.5	V
Vih4	-	1.93	-	2.75	V
Voh4	-2mA	2.2	-	2.75	V
Vol4	2mA	0	-	0.6	V
Iil input leakage		-5	-	+5	uA
Iol output leakage		-5	-	+5	uA

Notes

- IO Type 1 & 2
These user I/O port pins are rated to withstand voltages in the range -0.3V to +5.5VDC
- IO Type 3 – covers Z8 port H (ADC inputs; no series resistors)
These user inputs are for analogue voltage measurements only and must only be used within the working voltage range of -0.3V to 3.6VDC. They are not 5V compliant.
- IO Type 4 – covers GR47 “Digital 2.75V” IO
These logic inputs/ outputs are powered from an internal 2.75V ± 5 % internal voltage regulator and can tolerate the following

Filename	UWEBL_DM.DOC	Document Revision	1.7
Date of Issue	29 March 2007	Page Number	Page 65 of 71

- all 2.75 V digital inputs will continuously withstand and suffer no damage in the power-on or power-off condition when subjected to any voltage from - 0.5 V to 3.47 V (3.3 V + 5 %).
- all 2.75 V digital outputs will continuously withstand a short circuit to any other voltage within the range 0 V to 3 V.

4. I/O Type 5 (GSM Audio)

- all analogue outputs will continuously withstand a short circuit to any voltage within the range 0 V to 3 V.

11.2 Current Consumption

The current drawn by the uWEB Lite GSM/GPRS module is dependent on a number of parameters as follows:

- The specific variant product i.e.TTL OR RS232
- Operating state e.g. is the RS232 interface awake
- Operating mode (as detailed below)

Please note that before invoking any conditional states you will need to enter the following configuration:

```
AT#PUS="UK/solabzs07"
AT#PPA="dauchifa"
AT#RIP="209.142.3.2"
AT#RPO="2222"
AT#D0="08450885336"
AT#CFG=3
```

Condition	Detail	Typical supply (5VDC)		
		Ave	Peak	Units
Normal operating mode		20	126	mA
GSM call in progress		150	172	mA
Sleep mode (GSM module on)	Sleep mode, with GSM wakeup sources – ring indicate, CLI match or incoming SMS	11.2	11.2	mA
Sleep mode (GSM module off)	Sleep mode, with no GSM wakeup sources	122	122	µA

Notes

- Unit tested for 600seconds
- Autonomous firmware build v4.12; F6422
- Sleep mode now supported on all builds from v4.12 onward via AT#WAK & AT#slp
- Sleep mode has brownout circuit disabled

11.3 Timing Characteristics

Parameter	Conditions	Min	Typ	Max	Units
Cold startup time	Initial powerup, discharged capacitors	-	-	4	secs
Warm start		-	-	8	secs
Reset recovery to data	Hold /MBRESET low for 100ms min then release	-	-	8	secs

Filename	UWEBL_DM.DOC	Document Revision	1.7
Date of Issue	29 March 2007	Page Number	Page 66 of 71

12 MECHANICAL SPECIFICATIONS

12.1 Plan View

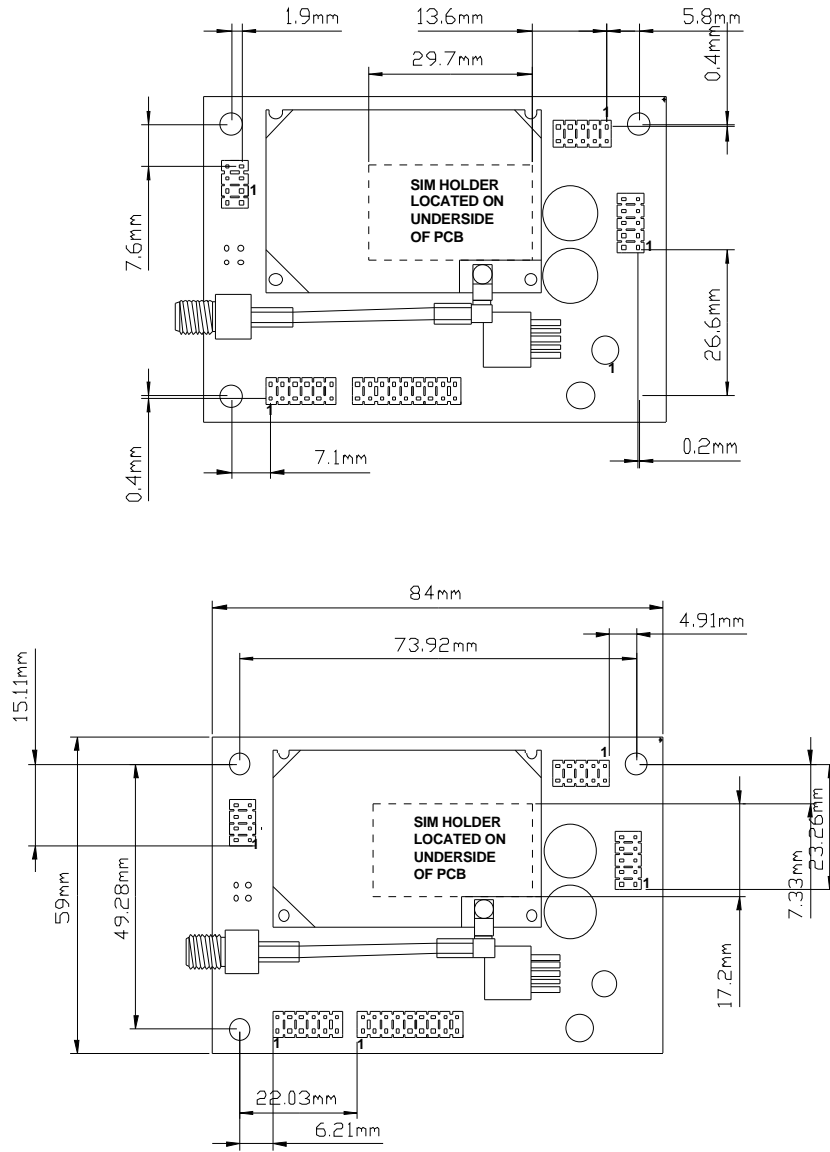

12.2 SMA Connector View

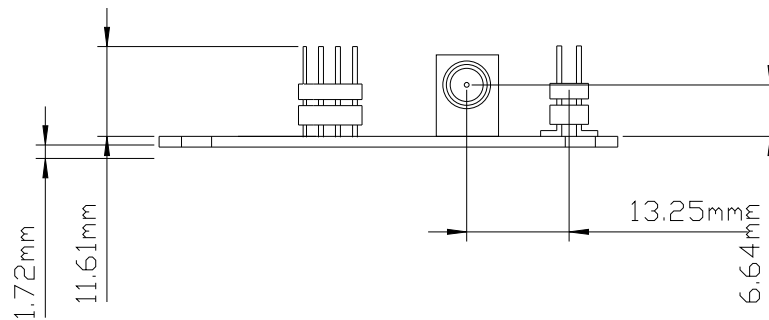

Filename	UWEBL_DM.DOC	Document Revision	1.7
Date of Issue	29 March 2007	Page Number	Page 67 of 71

13 APPROVALS IN EUROPE

The system integrator has to get CE marking for the integrated solution with the uWeb Lite module in Europe (GR47) and the FCC approval in the US (GR48). The system integrator only has to show compliance with the essential requirements of the module by the integration of it into the application.

If the external elements are designed according to the guidelines of this document the testing would be the following:

13.1 Integration with μWeb Lite for Europe

- EMC will need to be assessed in all modes of operation
- Safety

13.2 Integration with μWeb Lite for USA

- FCC approvals of all applicable parts

Comtech Holdings recommends that all these tests are performed by the customer in an accredited test house.

13.3 Documentation required

The system integrator is required to produce a document which will be submitted to the test house containing the following information.

- Summary of the application
- Hardware description
- Block diagram with an explanation
- Schematics
- PCB/Component layout
- Bill of materials

13.4 Power supply

It is essential the application power supply is designed to comply with the specification in section 2.2. Provided this is done then this should be sufficient to pass type approval without recourse to RF testing.

13.5 EMC & Safety Testing

EMC and safety tests according to the ITU/GSM and FCC standards will have to be completed as part of the mandatory testing. This is the responsibility of the system integrator. Overall ESD protection should be guaranteed by the system integrator.

The EMC standard which the application must be tested to is EN 301 489-7. A copy of this specification can be found at <http://www.etsi.org/getastandard/home.htm>.

The safety standard which the application must be tested to is EN 60950, the can be found at <http://www.iec.ch/>

For the GR48 FCC part 15 regulations, these can be found at <http://www.fcc.gov/>

Filename	UWEBL_DM.DOC	Document Revision	1.7
Date of Issue	29 March 2007	Page Number	Page 68 of 71

13.6 RF Testing

13.6.1 900/1800MHz variant for Europe (GR47)

As long as a passive antenna is used and of the correct impedance as specified in section 4.4 then no further RF testing is required.

13.6.2 850/1900MHz variant for USA (GR48)

According to the US rules (GR48) any change in RF path i.e. the antenna path will require new approval according to FCC part 22 and 24.

13.7 SAR warning

If the application is using an antenna which is less than 20cm away from the any part of the users body, integrators are legally obliged to publish SAR figures for the product. This testing would need to be carried out by the system integrator.

The GR48 module is FCC approved for fixed and mobile applications. If the final product after integration is intended for portable use, a new application and FCC ID is required.

Even if SAR measurements are not required it is considered good practice to insert a warning in any manual produced indicating it is a radio product and that care should be taken.

Filename	UWEBL_DM.DOC	Document Revision	1.7
Date of Issue	29 March 2007	Page Number	Page 69 of 71

14 PRODUCT ORDER CODES

Order Code	Product Name	Description
FG000071	µWEB Lite GSM/GPRS EUR TTL	900/1800MHz µWEB Lite GSM/GPRS TTL DATA/Audio/IO Port/RTC for Europe
FG000072	µWEB Lite GSM/GPRS EUR RS232	As above but with RS232 interface
FG000066	µWEB Lite GSM/GPRS EUR TTL Starter Kit	Starter kit for the FG000071
FG000078	µWEB Lite GSM/GPRS FCC TTL (full spec) module	850/1900MHz µWEB Lite GSM/GPRS TTL DATA/Audio/IO Port/RTC for USA
FG000079	µWEB Lite GSM/GPRS FCC RS232 (full spec) module	As above but with RS232 interface
FG000088	µsWEB Lite GSM/GPRS FCC TTL (full spec) Starter Kit	Starter kit for the FG000078

14.1 Accessories

Part No	Description
CABLE-004	MMCX to SMA PCB Mounting Cable Assembly for µWEB Lite
RS232-BRD-001	RS232/TTL converter board
CABLERIBBON10W	10 way TTL header cable
GSM-ANT-001	SMA Cell Block Antenna
GSM-ANT-003	MMCX Cell Block Antenna
PSU-EVAL1	230VAC to 9VDC/1.5A power supply (UK only)
PSU-0010	110-230VAC to 9V/1.5A power supply (complete with optional plugs for Europe and USA)
CABLE-DATA	Serial Cable 9w to 9w

Notes

- The RS232 variants of the µWEB Lite GSM/GPRS are not supported by the starter kits but are available to order from Comtech Holdings Ltd.
- Users looking to interface the µWEB Lite GSM/GPRS EUR RS232 module to a standard 9way D-type serial port will need to order accessory item CABLE-020 (9W DTYPE adapter cable) and CABLE-015 (power supply adapter lead for GPRS module)

Filename	UWEBL_DM.DOC	Document Revision	1.7
Date of Issue	29 March 2007	Page Number	Page 70 of 71

