

OEM-GPRS-2E GPRS & GSM DUAL BAND INTELLIGENT MODEM MODULE AUDIO and GPS COMPATIBLE

DESIGN MANUAL

<ul style="list-style-type: none"> • 5V TTL version, 5-15V RS232 Version • Data throughput up to 14400 bps • GPRS Class B Module 4+1 • HSCSD, 2 Downlink , 1 Uplink • 3/5V Serial TTL or RS232 Level Interface • Built in SIM socket • SMS support • FAX support • Configurable power down modes • Configurable wake events • Programmable SMS send events • Sleep power consumption 375uW 	<ul style="list-style-type: none"> • Dual band for use with all GSM networks using both 900MHz and 1800MHz • SMS support allowing messages of up to 160 characters to be sent and received. • Auto Answer on Ring Detect • Small mechanical outline approx 59x89mm (Approx) • Extended AT & AT+ command set • -20°C to 55°C operating Temperature Range
--	---

The OEM-GPRS-2 is the first of Comtech's next generation of intelligent GSM and GPRS communications modules. Optional support is available for audio and GPS.

Using the very latest GSM/GPRS technology together with onboard intelligence, very low power modes, suitable for long-term battery use, are standard. This together with configurable wake event, auto send of SMS makes the OEM-GPRS-2 ideal for applications where communications is required but is not supported by the host equipment.

This product was specifically designed for use in embedded modem applications where space, performance and power consumption, ease of use and fast time to market are key requirements.

Project Code	OEM-GPRS-2E	Title	OEM-GPRS-XXXX Design Manual
Revision	2.2	Document Type	Design manual
Issue Date	11/01/05	Page 1 of 20	



OEM-GPRS-2E

EMBEDDED INTELLIGENT MODEM

Hayes is a trademark of Hayes Microcomputer Products Inc.

All other product names are copyright and registered trademarks/trade names of the respective owners.

Comtech Holdings reserves the right to alter the specification of the products described in this manual at any time and without prior notice.

This document is copyrighted and may not, in whole or part, be copied, photocopied, reproduced, translated or reduced to any electronic or machine readable form without prior consent in writing from Comtech Holdings Ltd.

All rights reserved © 2004 Comtech Holdings Ltd

Any queries regarding information in this manual, please contact the Comtech Holdings Ltd at the address on the front page. Information provided in this document is believed correct at time of printing but is subject to change without notice. Comtech will not accept liability for any loss, damage or costs howsoever caused as a result of the information provided.

Project Code	OEM-GPRS-2E	Title	OEM-GPRS-XXXX Design Manual
Revision	2.2	Document Type	Design manual
Issue Date	11/01/05	Page 2 of 20	



1	Introduction	4
2	HOST DESIGN GUIDELINES	5
2.1	MOUNTING THE PCB	5
2.2	POWER SUPPLY	5
2.3	J1 SPECIFICATION	6
2.3.1	<i>/RESET</i>	6
2.3.2	<i>DGND</i>	6
2.3.3	<i>Data Levels</i>	7
2.4	SIM	8
3	CONNECTOR INFORMATION	9
3.1	CONNECTOR LAYOUT	9
3.2	PIN HEADERS	9
3.3	AUX POWER IN CONNECTOR	10
3.4	ANTENNA CONNECTOR	10
3.5	SIM CONNECTOR	10
4	HEADER DESCRIPTIONS	11
4.1	POWER AND DATA HEADER – J1 (& J2)	11
4.2	AUDIO HEADER – J4	12
4.2.1	<i>Audio To Mobile Station – ATMS</i>	12
4.2.2	<i>Audio From Mobile Station - AFMS</i>	13
4.3	MICROPHONE SIGNALS	14
4.3.1	<i>Speaker Signals</i>	14
4.4	INTERFACE HEADER – J6	15
4.4.1	<i>GPS interface</i>	15
4.4.2	<i>Real Time Clock</i>	16
4.4.3	<i>A/D Converter</i>	16
4.5	NETWORK STATUS & RTC – J7	16
4.6	AUX POWER IN	17
4.7	GSM/GPRS ANTENNA CONNECTOR	17
5	COMTECH MMCX TO SMA CABLES	19
5.1	CABLE-004	19
5.2	CABLE-006	19
6	ERICSSON GM47 AND GM48 CHARACTERISTICS	20
6.1.1	<i>GM47 Engine</i>	20
6.1.2	<i>GM48 Engine</i>	20

Table of Figures

Figure 1:	OEM-GPRS Connector Layout	9
Figure 2:	Microphone connections to module	14

1	Project Code	OEM-GPRS-2E	Title	OEM-GPRS-XXXX Design Manual
	Revision	2.2	Document Type	Design manual
	Issue Date	11/01/05	Page 3 of 20	



Introduction

The OEM-GPRS-2E is a GSM and GPRS intelligent modem module for internally embedded modem applications.

Supported features are:

- Extended AT Command Set
- TTL or RS232 Compatible Serial Host Interface
- Internal SIM card socket for 3V or 5V SIM's.
- GM47: 900/1800MHz
- GM48: 850/1900MHz
- Data Support
 - GPRS (general packet radio service, Class B 4+1)
 - CSD, (circuit switched data at 9600 baud)
 - HSCSD (high speed circuit switch data one slot uplink, two slots downlink per frame 2+1)
- SMS to GSM 03.40.
- SMS status reports to GSM 03.40
- SMS modes supported MO, (mobile originated), MT (mobile terminated) & CBM (cell broadcasts message)
- Class 1 FAX.
- Audio Support, using optional Audio/GPS Module.
 - HR (half rate),
 - FR (full rate)
 - EFR (enhance full rate)
- GPS Support, support for NMEA 0183 protocol using optional Audio/GPS Module.
- Configurable power down, standby and sleep modes.
- Configurable wake events and actions.

Project Code	OEM-GPRS-2E	Title	OEM-GPRS-XXXX Design Manual
Revision	2.2	Document Type	Design manual
Issue Date	11/01/05	Page 4 of 20	



2 Host Design Guidelines

2.1 Mounting The PCB

Care must be taken when designing the host equipment and mounting the OEM-GPRS to ensure that Regulatory Safety Approvals are NOT INVALIDATED.

Ensure that minimum CREEPAGE and CLEARANCE DISTANCES for HOST or other expansion modules and OEM-GPRS are maintained. Refer to the STATUTORY REQUIREMENTS section of this manual.

Ensure that the OEM-GPRS antenna socket is accessible with the HOST enclosure fitted and ensure that the antenna ground is NOT connected to the supply ground as this may result in damage to the unit. Antennas, which are through panel/chassis mounting and have a electrical connection to the panel/chassis should not be used. Suitable antennas are available from Comtech Ltd.

2.2 Power Supply

The power supply requirements differ across the range of OEM-GPRS modems, due to the interface voltage requirements.

	RS-232 Interface	TTL Interface
Input voltage:	4.75 to 15V DC.	4.75 to 5.25V DC.
Input current:	1.5A peak (600mA Average).	

Switcher or other DC supply noise should be less than 100mV peak to peak.

Due to the high current peak demand of GPRS the supply impedance and inductance to the OEM-GPRS modem must be kept to a minimum.

Supply of power using the 10 way IDC ribbon header is not recommended for ribbon cable length great than 10cm. For longer cable runs the aux power connector must be used, and suitable cable selected.

Given the low current standby modes of the OEM-GPRS modem, typically 15uA, care should be taken to ensure the regulations and stability of the power supply used.

Project Code	OEM-GPRS-2E	Title	OEM-GPRS-XXXX Design Manual
Revision	2.2	Document Type	Design manual
Issue Date	11/01/05	Page 5 of 20	



2.3 J1 Specification

The main communication with the module takes place via J1. This connector hosts power, data lines and /RESET. A version of the modem is available which has J1 connector re-located to the bottom-side of the board; in this instance the connector is termed J2.

Depending on the modem options the communication with the unit will use either RS-232 or TTL levels.

2.3.1 /RESET

The modem contains a reset system, which will generate an internal /RESET signal under the following conditions:

- J1-pin 10 being taken low for a minimum of 500mSec and then released,
- On-board 3v3 supply dropping below a pre-determined level,
- Power being applied to the board.

The signal placed on J1-10 is taken via a series diode before being pulled to 3v3 via a 470Ω resistor.

When J1-10 is taken low, a valid reset condition is entered, the on-board /RESET signal will be held low for a minimum of 140mSec after J1-10 is released.

J1-10 can be used to generate an reset by pulling the line low and then releasing, using either a push button or open collector transistor.

2.3.2 DGND

Note! *AGND and DGND are connected at a star point inside the GM47/48 engine. They must not be joined together in your application.*

Project Code	OEM-GPRS-2E	Title	OEM-GPRS-XXXX Design Manual
Revision	2.2	Document Type	Design manual
Issue Date	11/01/05	Page 6 of 20	



2.3.3 Data Levels

The OEM-GPRS can be specified to accept either TTL or RS-232 voltage levels for the data signals.

Care should be taken to ensure you use the correct levels for your particular board.

2.3.3.1 TTL Data Levels

The input lines to the board can handle both 3v and 5v signals.

	Min	Max
HIGH Level Input Voltage	2.4V	-
LOW Level Input Voltage	-	0.8V
HIGH Level Output Voltage	2.58V	-
LOW Level Output Voltage	-	0.1V

Note! *It is recommended that 3v signals are used to interface to this modem, to achieve the low currents in sleep modes.*

2.3.3.2 RS-232 Data Levels

The transmit output are 5.0V EIA/TIA-232 levels. Data rates are guaranteed to 250kbps with worst-case loads of 3k Ω in parallel with 1000pF.

The RS232 driver, in order to achieve low power operation, will auto shutdown approx 30 seconds after the last state change on any of the RS232 port signals.

In this shutdown state the output levels of the RS232 port will be at 0 volts. Any state change on the RS232 port, or from the network, which generates a transition or data, such as incoming ring, SMS etc will wake the RS232 driver from sleep .

For connection to a standard 9 way serial port an adaptor is available from Comtech or refer to <http://www.comtech.uk.com/Downloads/GsmGprsModems/OEM-GPRS-2E/AppNotes/Rs232cab.pdf>.

If auto shut down is not required contact Comtech for available options.

Project Code	OEM-GPRS-2E	Title	OEM-GPRS-XXXX Design Manual
Revision	2.2	Document Type	Design manual
Issue Date	11/01/05	Page 7 of 20	



Receiver Inputs

Parameter	Min	Typ	Max	Units
Input Voltage range	-25		25	Volts
Input Threshold Low	0.6	1.2		Volts
Input Threshold High		1.5	2.4	Volts

Transmitter Outputs

Parameter	Min	Typ	Max	Units
Output Voltage Swing	±5.0	±5.4		Volts
Output Resistance	300	10M		Ω
Output short-circuit current		±35	±60	mA
Output Leakage Current			±25	μA

All RS-232 inputs and outputs have enhanced ESD protection to ±15kV.

2.4 SIM

The SIM contains all of the information required to allow the unit to connect to the subscribers network. It is also used to store telephone numbers and SMS messages.

SIM's are usually NOT supplied data enabled. It is often possible to send data with a non-data enabled SIM but it is not possible to receive an incoming data call. A separate data number is often issued of the SIM is voice and data enabled.

This SIM interface allows the use of 3V and 5V SIM cards. By default it works on 3V levels but will automatically switch to 5V, if a 5V SIM card is fitted.

Note! *Check with your service provider to ensure that your SIM is enabled for the features you require (voice, data, GPRS etc)*

Project Code	OEM-GPRS-2E	Title	OEM-GPRS-XXXX Design Manual
Revision	2.2	Document Type	Design manual
Issue Date	11/01/05	Page 8 of 20	

3 Connector Information

3.1 Connector Layout

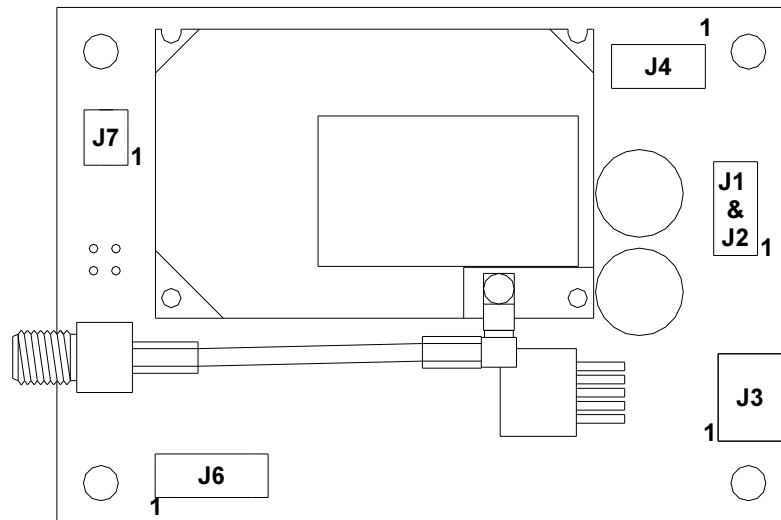

Figure 1: OEM-GPRS Connector Layout

Connector	Description
J1	Power and Data Header (top side)
J2	Power and Data Header (bottom side)
J3	Aux Power In
J4	Audio Header
J6	Interface Header
J7	Network Status and Real Time Clock (RTC)

3.2 Pin Headers

All the pin headers are set on a 2.54mm (0.1inch) pitch. To allow daughter boards to connect with the OEM-GPS board increased height board stacker connectors have been used. These connectors belong to the HW series manufactured by Samtec. A suitable cable assembly to mate with the J1 is Samtec IDSD-05-D-04.00.

Note! *Care should be taken if non-approved connectors are used with the HW series connectors as the stacker bar can be pushed down.*

Project Code	OEM-GPRS-2E	Title	OEM-GPRS-XXXX Design Manual
Revision	2.2	Document Type	Design manual
Issue Date	11/01/05	Page 9 of 20	



3.3 Aux Power In Connector

The AUX power connector is a two-pin screw terminal (5mm pitch), capable of accepting a maximum wire size of 2.5mm².

3.4 Antenna Connector

The GSM47/48 engine uses a micro-miniature coaxial MMCX connector. Comtech offers various solutions to convert this to a more useable SMA connector, see section 5 - Comtech MMCX to SMA Cables.

3.5 SIM Connector

The SIM connector is located on the underside of the module PCB.

Note! *Before handling the SIM card in your application, ensure that you are not charged with static electricity. Use proper precautions to avoid electrostatic discharges. The module must be switched off before the SIM card is installed in your application.*

Note! *When the SIM card hatch is opened, the SIM card connectors lie exposed under the SIM card holder. CAUTION: Do not touch these connectors! If you do, you may release an electrical discharge that could damage the module or the SIM card.*

Project Code	OEM-GPRS-2E	Title	OEM-GPRS-XXXX Design Manual
Revision	2.2	Document Type	Design manual
Issue Date	11/01/05	Page 10 of 20	



4 Header Descriptions

Refer to Figure 1: OEM-GPRS Connector Layout, for header locations.

4.1 Power and Data Header – J1 (& J2)

Pin	Name	Description
1	VIN	This input provides positive supply to the OEM-GPRS-2E. The power supply connected to this pin must meet the criteria as stated in this manual.
2	DGND	This input provides the supply return (0 Volts). All measurements with regards to supply voltages should be made reference to this pin.
3	RXD	Is used to transmit the data from the modem to the host at the selected baud rate.
4	TXD	Is used to receive data coming from the host to the modem at the selected baud rate.
5	/DTR	Is used by the host device to indicate that the host is ready to communicate. If DTR is CLEAR on the modem no communication will be possible.
6	/DCD	This control line is often used to indicate a connection with the remote modem.
7	/RTS	Is used to halt data from the modem should the host internal buffers become full and is cleared when the buffers have emptied sufficiently for transmission to resume.
8	/CTS	Is used to halt data from the host should the modem internal buffers become full and is cleared when the buffers have emptied sufficiently for transmission to resume.
9	/RI	This control line indicates the presence of an incoming call. The line will SET when the RING commences and remain SET throughout the RING events. Once the call is disconnected the line will return to CLEAR.
10	/RESET	This input allows remote disconnection of the modem power. Under normal conditions this pin is either left floating or held at > 3.3 volts (15 volts maximum). If this input is taken to 0 volts the onboard microprocessor will restart the GPRS Module. If a RESET is performed this input must be held at 0 volts for at least 500mS.

All control and data lines are labelled with reference to the HOST (DTE).

Note! *J1 is fitted as standard. J2 is an option fit.*

Note! *The function of RTS and CTS can be set by the AT+IFC command. This command also allows software flow control (XON / XOFF).*

Note! *Signals are 3v TTL volt logic. All inputs are protected and will accept up to 5v TTL logic levels. Control lines are SET at 0 volts and CLEAR at 3 volts.*

Note! *If software flow control (XON / XOFF) is used the hardware control lines must be held in the SET state. If the OEM-GPRS-2E is controlled from a Windows application or system it is recommended that hardware flow control is used.*

Project Code	OEM-GPRS-2E	Title	OEM-GPRS-XXXX Design Manual
Revision	2.2	Document Type	Design manual
Issue Date	11/01/05	Page 11 of 20	



4.2 Audio Header – J4

Note! *AGND and DGND are connected at a star point inside the GM47/48 module. They must not be joined together elsewhere.*

Pin	Name	Dir	Description
9	AFMS	OUT	Audio from mobile station
7	ATMS	IN	Audio to mobile station
6	AGND		Ground (return) for analogue audio

ATMS is the audio input, and AFMS is the audio output, of the module. These signals can be used in Hands-free or Portable Hands-free mode.

Hands-free Mode

This mode is used for audio accessories, such as car kits and hands-free equipment.

Portable Hands-free Mode

This is the default mode. It activates a different amplification factor in the ME, and activates a 2V microphone bias level for ATMS. The bias level is adjustable using AT*E2EAMS.

4.2.1 Audio To Mobile Station – ATMS

ATMS is the analogue audio input to the module. Internally, the signal is sent to the CODEC (COder/DECoder), where it is converted to digital audio in PCM (Pulse Code Modulation) format. The encoded audio is sent to PCMOOUT via the internal PCM bus.

ATMS provides a DC bias when it is used as the microphone input in Portable Hands-free applications. All other sources must be a.c.-coupled to avoid attenuation of low frequencies, and to prevent incorrect biasing or damage to the ATMS input. Use a capacitor greater than the value shown in the table below.

The ATMS input is a passive network followed by the transmit part of the CODEC.

Parameter		Limit
Application driving impedance (0.3 - 3.5kHz)		$\leq 300\Omega$
AC coupling capacitance ¹		$\geq 1\mu\text{F}$
Module input impedance (0.3 - 3.5kHz)		$> 50\text{k}\Omega$
Low frequency cut-off (-3dB)		$300\text{Hz} \pm 50\text{Hz}$
High frequency cut-off (-3dB)		$> 3500\text{Hz} \pm 50\text{Hz}$
Output d.c. bias level	Hands-free mode	0V
	Portable hands-free mode	$2.0\text{V} \pm 0.1\text{V}$
Additional Gain in Portable hands-free mode		28.5dB

¹ The a.c.-coupling capacitance must be supplied by your application, unless a d.c.-coupled microphone is used.

Project Code	OEM-GPRS-2E	Title	OEM-GPRS-XXXX Design Manual
Revision	2.2	Document Type	Design manual
Issue Date	11/01/05	Page 12 of 20	



The following tables show the nominal PGA (programming gain settings). For more information see the relevant AT commands.

Maximum input voltage limit: $245\text{mV}_{\text{rms}}$

Input	Input (mV_{rms})	TXAGC(dB)	AUX AMP gain	PCMOUT (dBm0)
ATMS	245	0	13	3

Maximum input level at MICI, $61.4\text{mV}_{\text{rms}}$ output at PCMOUT = 3dBm0

Input	Differential Input (mV_{rms})	TXAGC(dB)	AUX AMP gain	PCMOUT (dBm0)
MICN/MICP	61.4	0	25	3

Output at AFMS for 3dBm0 at PCMIN

Input	dBm0	RXPGA	Volume Control (dB)	AFMS(mV_{rms})
PCMIN	3	0	0	436

Output at BEARN/BEARP for 3dBm0 at PCMIN

Input	dBm0	RXPGA	Volume Control (dB)	BEAR(mV_{rms})
PCMIN	3	0	0	388

4.2.2 Audio From Mobile Station - AFMS

AFMS is the analogue audio output from the module and may be used to drive a speaker or the earpiece in a portable hands-free accessory.

The table below shows the audio signal levels for AFMS.

Parameter		Limit
Speaker impedance		64Ω to $1\text{K}\Omega$
Output Capacitance		$2.2\mu\text{F} \pm 10\%$
Levels (THD <5%)	Drive capability into $5\text{k}\Omega$ (0.3 to 3.5kHz)	$> 2.4 V_{\text{p-p}}$
	Drive capability into $1.5\text{k}\Omega$ (0.3 to 3.5kHz)	$> 2.2 V_{\text{p-p}}$
	Drive capability into 150Ω (at 1kHz)	$> 1.3 V_{\text{p-p}}$

Project Code	OEM-GPRS-2E	Title	OEM-GPRS-XXXX Design Manual
Revision	2.2	Document Type	Design manual
Issue Date	11/01/05	Page 13 of 20	

4.3 Microphone Signals

Pin	Name	Dir	Function
2	MICP	IN	Microphone positive input
3	MICN	IN	Microphone negative input

MICP and MICN are balanced differential microphone input pins. These inputs are compatible with an electret microphone. The microphone contains an FET buffer with an open drain output, which is supplied with at least +2V relative to ground by the module as shown below.

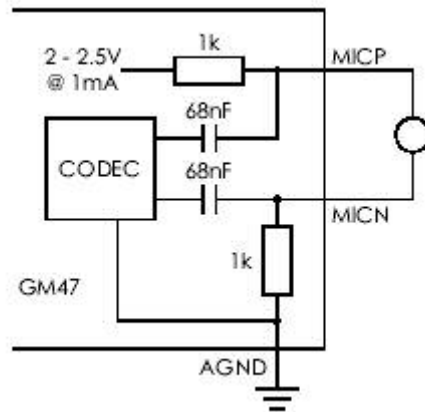

Figure 2: Microphone connections to module

4.3.1 Speaker Signals

Pin	Name	Dir	Function
4	BEARP	OUT	Speaker positive output
5	BEARN	OUT	Speaker negative output

BEARP and BEARN are the speaker output pins. These are differential-mode outputs. The electrical characteristics are given in the table below.

Parameter	Limit
Output level (differential)	$\geq 4.0 V_{p-p}$
Output level (dynamic load = 32Ω)	$\geq 2.8 V_{p-p}$
Gain PCMIN to BEARP/BEARN (differential)	$-9dB \pm 1$
Distortion at 1kHz and maximum output level	$\leq 5\%$
Offset, BEARP to BEARN	$\pm 30mV$
Ear-piece mute-switch attenuation	$\geq 40 dB$

Project Code	OEM-GPRS-2E	Title	OEM-GPRS-XXXX Design Manual
Revision	2.2	Document Type	Design manual
Issue Date	11/01/05	Page 14 of 20	



The following table shows the earpiece impedances that can be connected to BEARP and BEARN.

Ear Piece	Impedance	Tolerance
Dynamic ear piece	$[32\Omega + 800 \mu\text{H}] // 100 \text{ pF}$	$\pm 20\%$
Dynamic ear piece	$[150\Omega + 800 \mu\text{H}] // 100 \text{ pF}$	$\pm 20\%$
Piezo ear piece	$1\text{k}\Omega + 60 \text{ nF}$	$\pm 20\%$

4.4 Interface Header – J6

Note! *The information in this section is provided for reference. The signals on this header are not under the control of the end-user.*

J6 is a multi-purpose Header. The individual features of this connector are detailed below in the relevant sub-sections.

4.4.1 GPS interface

Pin	Name	Direction	Description
1	VIN_FILTERED	OUT	Filtered power feed to the GPS board (from V_{IN})
7	MOSI	IN	Data from GPS Daughter board
8	MISO	OUT	Data to GPS Daughter board
9	SCK	OUT	GPS regulator enable signal
11	3v3	OUT	Supply to keep GPS alive when in sleep mode
12	DGND	-	

When the GPS daughter board is fitted the interface serves as an interface between the GPS can and the GPRS micro-controller.

The GPS board takes power from VIN_FILTERED and passed to an on-board regulator, which is under the control of ‘SCK’ allowing the GPRS micro-controller to turn the GPS engine on/off.

3v3 is passed on pin 11 to keep the GPS RTC and SRAM alive to allow the use of Warm and Hot starts.

Data to and from the GPS engine is passed using ‘MOSI’ and ‘MISO’.

Project Code	OEM-GPRS-2E	Title	OEM-GPRS-XXXX Design Manual
Revision	2.2	Document Type	Design manual
Issue Date	11/01/05	Page 15 of 20	



4.4.2 Real Time Clock

Pin	Name	Direction	Description
2	RTC_SDO	OUT	Serial Data Out
3	RTC_SDI	IN	Serial Data In
4	RTC_SCLK	IN	Serial Clock In
5	RTC_CE	OUT	Chip Enable
12	DGND	-	

Note! *Whilst the RTC is located on the GPRS board, the interface signals are brought out on the Interface header. The RTC is being accessed when RTC_CE is high.*

4.4.3 A/D Converter

Pin	Name	Direction	Description
6	ADC7	IN	A/D input channel
12	DGND	-	

- 10-bit Resolution successive approximation ADC
- 0.5 LSB Integral Non-linearity
- ± 2 LSB Absolute Accuracy
- 65 - 260 μ s Conversion Time
- Up to 15 kSPS at Maximum Resolution
- Optional Left Adjustment for ADC Result Readout
- 0 – 2.56 (ADV Reference Voltage) Input Voltage Range
- Free Running or Single Conversion Mode
- Interrupt on ADC Conversion Complete
- Input refers to 0V (DGND)

4.5 Network Status & RTC – J7

Pin	Name	Direction	Description
1	LED Anode	OUT	LED to signal status of GPRS can
2	LED Cathode	IN	LED to signal status of GPRS can
5	V _{RTC}	IN	RTC backup supply
6	DGND	-	

The GPRS module has an on-board GREEN LED. However, an external LED can be connected to J7.

LED indication		Operational status	
Project Code	OEM-GPRS-2E	Title	OEM-GPRS-XXXX Design Manual
Revision	2.2	Document Type	Design manual
Issue Date	11/01/05	Page 16 of 20	



Off	No power or in the OFF state
Steady	Power on, not connected to a network
Blinking	Power on, connected to a network

V_{RTC} is supplied directly to the on-board RTC (if fitted). The RTC is supplied from an on-board 3v3 regulator. If the output from this regulator should fall below the voltage on V_{RTC} the RTC will be write-protected. The RTC is fully accessible when the 3v3 voltage is greater than $V_{RTC}+0.2V$.

Note! *V_{RTC} should be supplied from a non-rechargeable Lithium Battery or other suitable power source. There is no facility for charging the source.*

4.6 AUX Power In

Pin	Name	Description
1	DGND	This input provides the supply return (0 Volts). All measurements with regards to supply voltages should be made reference to this pin.
2	VIN	This input provides positive supply to the OEM-GPRS-2E. The power supply connected to this pin must be meet the criteria as stated in this manual.

Note! *Supply of power using J1/J2 connector is not recommended for ribbon cable length great than 10cm. For longer cable runs the AUX Power In connector must be used, and suitable cable selected.*

4.7 GSM/GPRS Antenna Connector

The module's antenna connector allows transmission of the radio frequency (RF) signals from the module to an external antenna. The connector is a micro-miniature coaxial MMCX surface mounted component. A number of suitable MMCX type, mating plugs are available from the following manufacturers;

- Amphenol;
- Suhner;
- IMS Connector Systems.

The electrical characteristics of the antenna interface are shown below.

Parameter	Limit	Description
Nominal impedance	50Ω (better than 2:1)	
Output Power	2 Watt peak (Class 4)	Extended GSM900
	1 Watt peak (Class 1)	GSM1800
Static Sensitivity	Better than -104dBm	Extended GSM900
	Better than -102dBm	GSM1800

Project Code	OEM-GPRS-2E	Title	OEM-GPRS-XXXX Design Manual
Revision	2.2	Document Type	Design manual
Issue Date	11/01/05	Page 17 of 20	



Comtech sell a number of antennas with MMCX terminations and also a range of adapter cables to convert from the MMCX to a SMA connector. Please refer to Section 5 - Comtech MMCX to SMA Cables .

Project Code	OEM-GPRS-2E	Title	OEM-GPRS-XXXX Design Manual
Revision	2.2	Document Type	Design manual
Issue Date	11/01/05	Page 18 of 20	



5 Comtech MMCX to SMA Cables

The Ericsson GM47/48 engine utilise a MMCX (micro-miniature coaxial) for the antenna connector. Due to the small size of these connectors COMTECH have manufactured a number of cable assemblies to allow the use of SMA type connectors. These are ordered separately and details are given below.

5.1 Cable-004

This cable assembly consists of a right-angled MMCX plug, a 40mm RG316 cable and a PCB mount SMA Jack. The SMA connector is designed to mount directly to the OEM-GPRS PCB.

5.2 Cable-006

This assembly consists of a right-angled MMCX plug, a 130mm RG316 cable and a bulkhead mounted SMA Jack.

Project Code	OEM-GPRS-2E	Title	OEM-GPRS-XXXX Design Manual
Revision	2.2	Document Type	Design manual
Issue Date	11/01/05	Page 19 of 20	



6 Ericsson GM47 and GM48 Characteristics

GM47 and GM48 are dual band mobile stations with the characteristics shown in the tables below.

6.1.1 GM47 Engine

	GSM900	E-GSM900	GSM1800
Frequency range (MHz)	TX: 890 – 915 RX: 935 – 960	TX: 880 – 890 RX: 925 – 935	TX: 1710 – 1785 RX: 1805 – 1880
Channel spacing	200kHz		200kHz
Number of channels	173 carriers * 8 (TDMA) GSM: channels 1 to 124 E-GSM: channels 975 to 1023		374 carriers *8 (TDMA) DCS: channels 512 to 885
Modulation	GMSK		GMSK
TX phase accuracy	<5° RMS phase error (burst)		<5° RMS phase error (burst)
Duplex spacing	45 MHz		95 MHz
Receiver sensitivity at antenna connector	<-102dBm		<- 102dBm
Transmitter output power at antenna connector	Class 4 2W (33dBm)		Class 1 1W (30dBm)
Automatic hand-over between GSM900 and GSM1800			

6.1.2 GM48 Engine

	GSM850	GSM1900
Frequency range (MHz)	TX: 824 – 849 RX: 869 - 894	TX: 1850 - 1910 RX: 1930 – 1990
Channel spacing	200kHz	
Number of channels	123 carriers * 8 (TDMA) GSM: channels 128 to 251	298 carriers *8 (TDMA) PCS: channels 512 to 810
Modulation	GMSK	
TX phase accuracy	<5° RMS phase error (burst)	
Duplex spacing	45 MHz	80 MHz
Receiver sensitivity at antenna connector	<-102dBm	
Transmitter output power at antenna connector	Class 5 0.8W (29dBm)	Class 1 1W (30dBm)
Automatic hand-over between GSM850 and GSM1900		

Project Code	OEM-GPRS-2E	Title	OEM-GPRS-XXXX Design Manual
Revision	2.2	Document Type	Design manual
Issue Date	11/01/05	Page 20 of 20	