



OEM-MODEM-56C2/34C2/32C2/24C2

HIGH SPEED MODEM MODULE

WITH CALLER ID DECODE

DESIGN MANUAL

FEATURES

Part No	Data Modem Format	Maximum Data Rate (bit/sec)	Caller ID Decode	On & Off Hook Parallel Phone Detect
OEM-MODEM-56C2	ITU V90	56,000	✓	✓
OEM-MODEM-34C2	ITU V34	33,600	✓	✓
OEM-MODEM-33C2	ITU V32bis	14,400	✓	✓
OEM-MODEM-24C2	ITU V22bis	2400	✓	✓

- Data modem formats
 - ITU-T, Bell
 - 300 bps up to 56,000 bps
 - Automatic rate negotiation
 - Caller ID decode
 - On-hook & Off-hook Parallel phone detection
 - Worldwide operation
 - V42 Error correction (LAPM & MNP4)
 - V.42bis & MNP5 data compression
 - MNP2-5
 - Hayes AT-command compatible
 - Autobauding up to 307.2 kbps
 - Non volatile storage for default settings, firmware upgrades, and user-defined AT command macros
 - TTL input, 3.3V output serial Interface
 - RJ11 Network connection
 - Small mechanical outline 2.3"x3.27"
 - Single +5v DC Power Supply
 - 0°C to 70°C Commercial Temperature Range
 - Sleep mode.
 - Reduces power consumption to typically 3mA*. Recovers via ring detection, transmit data (TxD) and reset.
 - Power down mode.
 - Reduces power consumption to typically 760µA*. Recovers via reset.
- * advanced characterisation data (to be confirmed)

The OEM-MODEM-xxC2 family of modem modules are designed for embedded modem applications that require low power consumption, small footprint and global compliance.

OEM-MODEM-xxC2 modems provide a TTL compatible serial interface to the host Data Terminal Equipment (DTE). The serial interface is capable of autobauding up to 307.2KHz.

OEM-MODEM-xxC2 modems offer a range of connection speeds, enhanced with V.42Bis/MNP5 data compression and V.42 (LAPM & MNP4) error correction protocols to ensure error free data transfer over the Public Switched Telephone Network (PSTN).

Call control is provided using the Hayes AT Command Set. OEM-MODEM-xxC2 modems are capable of DTMF auto-dial and auto-answer based on ring detection. Both on-hook and off-hook parallel phone detection are supported, to prevent the modem seizing the line whilst the parallel phone is off-hook.

Filename	OEM-MODEM-XX2C	Document Revision	1.1
Date of Issue	18/02/2005	Page Number	1 of 61

OEM-MODEM-56C2/34C2/32C2/24C2 EMBEDDED MODEMS

The OEM-MODEM-xxC2 family of modems have been designed in accordance with TBR-21 for pan-European single terminal connection to the Public Switched Telephone Network (PSTN). However, due to differences between the individual PSTNs provided in different countries, the approval does not, of itself, give an unconditional assurance of successful operation on every PSTN network termination point.

The OEM-MODEM-xxC2 family of modems are designed to work with networks in the following countries:

Argentina, Australia, Austria, Bahrain, Belgium, Bolivia, Brazil, Canada, Chile, China, Colombia, Costa Rica, Cyprus, Czechoslovakia, Denmark, Ecuador Egypt Finland France, Germany, Greece, Guatemala, Hong Kong Hungary, India, Indonesia, Ireland Israel, Italy, Japan, Korea, Kuwait Lebanon Malaysia, New Zealand, Netherlands, Norway, Oman, Panama, Peru, Philippines, Poland, Portugal, Puerto Rico, Russia, Saudi Arabia, Spain, Singapore, Slovakia, South Africa, Sweden, Switzerland, Taiwan, Thailand, Trinidad, Turkey Uruguay, UAE, USA, UK, and Venezuela.

For detailed information on connecting the modem to a network in one of the supported countries, please refer to the "OEM-MODEM-xxC2: Country Settings" application guide.

It should be noted that adjusting transmission power level settings and timing parameters on these modems from the default settings may cause this product to fail to meet the essential requirements of the TE Directive.

Hayes is a trademark of Hayes Microcomputer Products Inc.

All other product names are copyright and registered trademarks/trade names of the respective owners.

Complementary Technologies reserves the right to alter the specification of the products described in this manual at any time and without prior notice.

This document is copyrighted and may not, in whole or part, be copied, photocopied, reproduced, translated or reduced to any electronic or machine readable form without prior consent in writing from Comtech Holdings Ltd.

All rights reserved, © 2004, Comtech Holdings Ltd

Printed in England

Issue 1.0

Filename	oem-modem-xxc2.doc	Document Revision	1.5
Date of Issue	18/02/2005	Page Number	2 of 61

Contents

1	Specification Summary	6
2	Functional Description.....	9
2.1	Serial Host Interface.....	9
2.1.1	Command Mode.....	9
2.1.2	Data Mode	9
2.1.3	Escape Methods.....	10
2.2	Data Compression	10
2.3	Error Correction	11
2.4	Wire Mode	11
2.5	Fast Connect	12
2.5.1	V.29 Fast Connect.....	12
2.5.2	Transparent HDLC/Synchronous DCE Mode	13
2.6	Intrusion Detection	15
2.6.1	On-Hook Line-in-Use Detection	15
2.6.2	Off-Hook Intrusion Detection.....	15
2.7	Over Current Detection	16
2.8	Caller ID Operation	16
2.9	Global Operation.....	16
2.10	Low Power Modes	16
2.11	Firmware Upgrades	16
2.12	EEPROM Interface	16
3	AT Commands.....	17
3.1	AT Commands Reference.....	18
3.1.1	\$ Display AT command mode settings.....	18
3.1.2	A Answer Command.....	18
3.1.3	A/ Repeat Last Command.....	18
3.1.4	Dn Dial Command	18
3.1.5	En Echo Command	19
3.1.6	Hn Hook Control.....	19
3.1.7	In Request ID Information.....	19
3.1.8	Mn Speaker operation	20
3.1.9	On Return On-line to Data Mode	20
3.1.10	Qn Result Code Control.....	20
3.1.11	Vn Verbal Response Format.....	21
3.1.12	Xn Call Progress Monitoring	21
3.1.13	Yn Long Space Disconnect.....	21
3.1.14	Z Hard Reset.....	21
3.1.15	+VCID= <i>n</i> Caller ID Control.....	22
3.1.16	+VCDT= <i>n</i> Caller ID Type.....	22
3.1.17	+FCLASS= <i>n</i> Class 1 Modem Enabled.	22
3.1.18	+FTM= <i>n</i> Class 1 Transmit Carrier.....	23
3.1.19	+FRM= <i>n</i> Class 1 Receive Carrier.	23
3.1.20	+GCI= <i>n</i> Country Settings.....	23
3.1.21	%%\$ Display AT% command settings.....	24
3.1.22	%C <i>n</i> Data compression	24
3.1.23	%On Answer mode.....	24
3.1.24	%V <i>n</i> Automatic Line Status Detection.....	24
3.1.25	:E EEPROM Read.....	26
3.1.26	:I Interrupt Read	26
3.1.27	:M EEPROM Write.....	26
3.1.28	:P Program RAM Write	27
3.1.29	:R User-Access Register Read	27
3.1.30	:U User-Access Register Write	27
3.1.31	&\$ Display AT& current settings.	28
3.1.32	&D <i>n</i> DTR Mode.....	28

Filename	oem-modem-xxc2.doc	Document Revision	1.5
Date of Issue	18/02/2005	Page Number	3 of 61

3.1.33	&Gn Line connection rate limit	28
3.1.34	&Hn Switched network handshake mode	29
3.1.35	&Z low-power mode	29
3.1.36	\\$ Display AT\ command settings	30
3.1.37	\Bn Character length	30
3.1.38	\Wn Asynchronous protocol	30
3.1.39	\Pn Parity type	31
3.1.40	\Qn Modem-to-DTE flow control	31
3.1.41	\Tn DTE speed	31
3.1.42	\Vn Connect message type	32
4	S-Registers	35
4.1	S-Registers Reference	36
4.1.1	S0 Auto Answer Ring Number	36
4.1.2	S1 Ring Counter	36
4.1.3	S2 AT Escape Character (User Defined)	36
4.1.4	S4 Response Formatting Character (User Defined)	37
4.1.5	S5 Command Line Editing Character (User Defined)	37
4.1.6	S6 Wait Before Dialling	37
4.1.7	S7 Connection Completion Time-Out	38
4.1.8	S8 Comma Dial Modifier Time	38
4.1.9	S9 Carrier Presence Timer	38
4.1.10	S10 Automatic Disconnect Delay	38
4.1.11	S12 Escape Guard Time	39
4.1.12	S14 Dial Tone Detection Time	39
4.1.13	S24 Sleep Inactivity Time	39
4.1.14	S30 Inactivity Timer	39
4.1.15	S38 Hang Up Delay Timer	40
4.1.16	S40 Data Pattern	40
4.1.17	S41 V.34 Symbol Rate	40
4.1.18	S43 Dial attempts to Blacklist	41
4.1.19	S44 Blacklist Timer	41
4.1.20	S50 Minimum On-hook Time	41
4.1.21	S51 Outside Number	41
5	User-Access Registers (U-Registers)	42
5.1	User-Access Bitmapped Reference	46
U4D	MOD1	46
U53	MOD2	47
U62	DAAC1	47
U65	DACC4	47
U66	DACC5	48
U67	ITC1	48
U68	ITC2	49
U69	ITC3	50
U6A	ITC4	51
U6E	CK1	51
U70	IO0	52
U76	GEN1	53
U77	GEN2	53
U78	GEN3	54
U79	GEN4	54
U7A	GENA	55
U7C	GENC	55
U7D	GEND	56

Filename	oem-modem-xxc2.doc	Document Revision	1.5
Date of Issue	18/02/2005	Page Number	4 of 61

6 CONNECTOR SPECIFICATIONS..... 57

6.1 SERIAL HOST INTERFACE 57

6.2 HOST INTERFACE DESCRIPTION..... 57

6.3 TELEPHONE CONNECTION..... 58

7 ELECTRICAL CHARACTERISTICS 59

7.1 DC Electrical Characteristics 59

7.2 Timing Characteristics..... 59

8 MECHANICAL SPECIFICATIONS..... 60

Filename	oem-modem-xxc2.doc	Document Revision	1.5
Date of Issue	18/02/2005	Page Number	5 of 61

Item	Specification
Data Format Bit asynchronous	Selectable 8, 9, 10, or 11 bits per character
Compatibility	ITU-T V.90 ¹ , V.34 ² , V.32bis, V.32, V.23, V.22bis, V.22, V.21, Bell 212A, and Bell 103
Operating Mode Switched network	Two-wire full duplex
Data Modulation 28 to 56 kbps ¹ 2.4 to 33.6 kbps ² 14.4 kbps 12.0 kbps 9600 bps 9600 bps 9600 bps 7200 bps 4800 bps 2400 bps 1200 bps 0 to 300 bps	V.90 as specified by ITU-T V.34 as specified by ITU-T 128-level TCM/2400 Baud $\pm 0.01\%$ 64-level TCM/2400 Baud $\pm 0.01\%$ 32-level TCM/2400 Baud $\pm 0.01\%$ 16-level QAM/2400 Baud $\pm 0.01\%$ 29 QAM as specified by ITU-T 16-level TCM/2400 Baud $\pm 0.01\%$ level QAM/2400 Baud $\pm 0.01\%$ 16-level QAM/600 Baud $\pm 0.01\%$ 4-level PSK/600 Baud $\pm 0.01\%$ FSK 0–300 Baud $\pm 0.01\%$
Answer Tone ITU-T V.32bis, V.32, V.22bis, V.22, and V.21 modes Bell 212A and 103 modes	2100Hz ± 3 Hz 2225Hz ± 3 Hz
Transmit Carrier V.901 V.342 ITU-T V.32bis ITU-T V.32 ITU-T V.22, V.22bis/Bell 212A Originate mode Answer mode ITU-T V.21 Originate mode Answer mode Bell 103 Originate mode Answer mode	As specified by ITU-T As specified by ITU-T 1800Hz $\pm 0.01\%$ 1800Hz $\pm 0.01\%$ 1200Hz ± 0.5 Hz 2400Hz ± 1 Hz Mark (980Hz ± 12 Hz) Space (1180Hz ± 12 Hz) Mark (1650Hz ± 12 Hz) Space (1850Hz ± 12 Hz) Mark (1270Hz ± 12 Hz) Space (1070Hz ± 12 Hz) Mark (2225Hz ± 12 Hz) Space (2025Hz ± 12 Hz)
Output Level Permissive—Switched network	–9 dBm maximum
Notes: 1. Supported on OEM-MODEM-56C2 only. 2. Supported on OEM-MODEM-56C2 and OEM-MODEM-34C2 only.	

Table 1.0: Specification Summary (continued)

Filename	oem-modem-xxc2.doc	Document Revision	1.5
Date of Issue	18/02/2005	Page Number	7 of 61

Item	Specification
Receive Carrier ITU-T V.901 ITU-T V.342 ITU-T V.32bis ITU-T V.32 ITU-T V.22, V.22bis/Bell 212A Originate mode Answer mode ITU-T V.21 Originate mode Answer mode Bell 103 Originate mode Answer mode	As specified by ITU-T As specified by ITU-T 1800Hz \pm 7Hz 1800Hz \pm 7Hz 2400Hz \pm 7Hz 1200Hz \pm 7Hz Mark (980Hz \pm 12Hz) Space (1180Hz \pm 12Hz) Mark (1650Hz \pm 12Hz) Space (1850Hz \pm 12Hz) Mark (2225Hz \pm 12Hz) Space (2025Hz \pm 12Hz) Mark (1270Hz \pm 12Hz) Space (1070Hz \pm 12Hz)
Carrier Detect (level for ITU-T V.22bis, V.22, V.21, 212, 103) in Switched Network	Acquisition (-43 dBm) Release (-48 dBm)
Hysteresis	2 dBm minimum
Note: ITU-T V.90 ¹ , V.34 ² , V.32/V.32bis are echo-canceling protocols that use signal quality as criteria for maintaining connection. They also provide for self-training detection to force disconnect.	
DTE Interface	EIA/TIA-232-E (ITU-T V.24/V.28/ISO 2110)
Line Equalization	Automatic Adaptive
Connection Options	Loss of Carrier in ITU-T V.22bis and lower
Phone Types	500 (rotary dial), 2500 (DTMF dial)
Dialing	Pulse and Tone
DTMF Output Level	Per Part 68
Pulse Dial Ratio	Make/Break: 39/61%
Ring Cadence	On 2 seconds; Off 4 seconds
Call Progress Monitor	BUSY CONNECT (rate) NO ANSWER NO CARRIER NO DIALTONE OK RING RINGING
Notes: 1. Supported on OEM-MODEM-56C2 only. 2. Supported on OEM-MODEM-56C2 and OEM-MODEM-34C2 only.	

Table 1.0: Specification Summary (continued)

Filename	oem-modem-xxc2.doc	Document Revision	1.5
Date of Issue	18/02/2005	Page Number	8 of 61

2 Functional Description

The OEM-MODEM-xxC2 family of modem modules are developed for use within embedded modem applications. The OEM-MODEM-xxC2 accepts standard modem AT commands and provides connect rates up to 56/33.6/14.4/2.4 kbps full-duplex over the Public Switched Telephone Network (PSTN). The OEM-MODEM-xxC2 features a complete set of modem protocols including all ITU-T standard formats up to 56 kbps.

The OEM-MODEM-xxC2 provides numerous additional features for embedded modem applications. The modem includes full caller ID detection and decoding for global standards. Call progress is supported through echoing result codes and is also programmable to meet global settings. The OEM-MODEM-XXC2 also includes features, such as parallel phone detect, over current detection, and global PTT compliance.

This device is ideal for embedded modem applications due to its small board space, low power consumption, and global compliance. The modem can be programmed to meet worldwide PTT specifications for AC termination, DC termination, ringer impedance, and ringer threshold. In addition, the modem has been designed to meet the most stringent worldwide requirements for out-of-band energy, billing-tone immunity, lightning surges, and safety requirements.

The OEM-MODEM-xxC2 is designed for rapid incorporation into existing modem applications. The device interfaces via a serial host connector to a micro-controller or to a PC through a standard RS-232 transceiver. This interface allows for PC evaluation of the modem immediately upon power up via the AT commands using standard terminal software.

2.1 Serial Host Interface

All OEM-MODEM-xxC2 modems have a 10-way header socket, which provides the serial interface to the host Data Terminal Equipment (DTE). This is a TTL input, 3.3V output signal level interface. This connector also provides the power source. The serial host interface supports DTE rates up to 307.2 kbps with the standard serial UART format. The OEM-MODEM-xxC2 supports automatic baud rate detection that allows the host to start transmitting data at any standard DTE rate from 300 bps to 307.2 kbps. The serial host interface is detailed in section 6.1. The serial host interface has two modes of operation:

2.1.1 Command Mode

Upon reset, the modem is in Command mode and accepts "AT" commands. An outgoing modem call can be made using the "ATDT#" (tone dial) or "ATDP#" (pulse dial) command after the device is configured. If the handshake is successful, the modem responds with the response codes detailed in table 3.1 and enters data mode.

2.1.2 Data Mode

The modem is in Data mode while it has a connection to another modem or is in the process of establishing a connection. In Command and Data mode, the OEM-MODEM-xxC2 operates in asynchronous DTE mode only. Data protocols are available to provide error correction to improve reliability (V.42 and MNP2-4) and data compression to increase throughput (V.42bis and MNP5), refer to sections 2.2 and 2.3.

Each connection between two modems in Data mode begins with a handshaking sequence. During this sequence, the modems determine the line speed, data protocol, and related parameters for the data link. Section 2.1.3 details how to escape from data mode.

Filename	oem-modem-xxc2.doc	Document Revision	1.5
Date of Issue	18/02/2005	Page Number	9 of 61

2.1.3 Escape Methods

There are four ways to escape from data mode and return to command mode once a connection is established. Three of these, “+++”, “9th Bit”, and DTR, allow the connection to be maintained while one or both modems are in the command mode. These three escape methods can be concurrently enabled, and any enabled escape method functions. For example, if “+++” and DTR are both enabled, either returns the modem to the command mode from the data mode. The fourth escape method is to terminate the connection.

Always wait for the “OK” before entering the next command after an escape. When making a new connection, do not try to escape between the connect message and the protocol message. An escape attempt in this interval may fail because the modem is not in data mode until after the protocol message.

“+++” Escape

The “+++” escape is enabled by default and is controlled by U70[13] (TES). There are equal guard time periods before (leading) and after (trailing) the “+++” set by the S-Register S12, during which there must be no UART activity. If this UART inactivity criterion is met, the modem escapes to the command mode at the end of the S12 time period following the “+++”. Any activity in the UART during either the leading or trailing time period causes the modem to ignore the escape request and remain in data mode. Timing for this escape sequence is shown below.

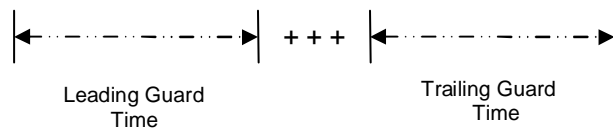

Guard Time = S12 (20 msec units)
 Default Guard Time S12 = 50 (1.0 sec)
 Guard Time Range = 10–255 (0.2–5.1 sec)

“9th Bit” Escape

The “9th Bit” escape mode feature is enabled by sending the AT\B6 command through autobaud, which detects a 9th bit space as “9th bit” escape mode. If this escape method is selected, a 1 detected on the ninth bit in a data word returns the modem to the command mode. The 9th bit is ignored when the modem is in the command mode. Timing for this escape sequence is shown below.

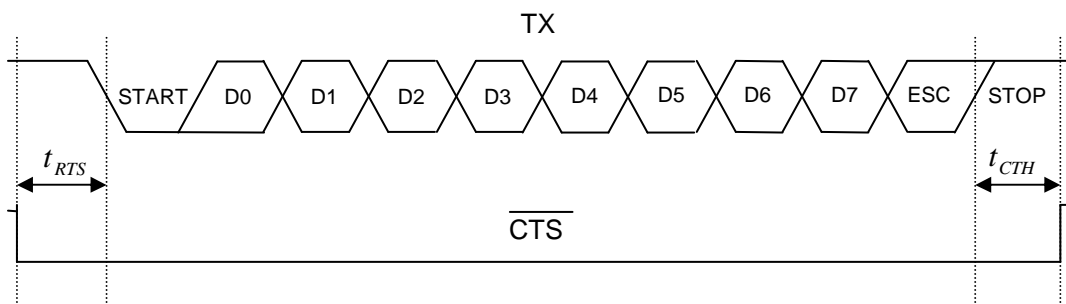

DTR Escape

The DTR action is controlled by U70[15] (HES). This bit is 0 by default, which disables the DTR Escape. If HES is set to a 1, a high level on DTR causes the modem to transition to the on-line command mode. The DTR pin status is polled by the modem, and there is a latency before the “OK” is received and the modem is in command mode. Keep DTR active until the “OK” is received.

2.2 Data Compression

Filename	oem-modem-xxc2.doc	Document Revision	1.5
Date of Issue	18/02/2005	Page Number	10 of 61

The OEM-MODEM-xxC2 modem can achieve DTE (host-to-modem) speeds greater than the maximum DCE (modem-to-modem) speed through the use of a data compression protocol.

The compression protocols available are the ITU-T V.42bis and MNP5 protocols. Data compression attempts to increase throughput by compressing the information to be sent before actually sending it. The modem is thus able to transmit more data in a given period of time. Table 2.0 details the OEM-MODEM-xxC2 error correction and data compression modes of operation. This feature is currently not supported on the OEM-MODEM-24C2.

To Enable	Use AT Commands
V.42bis V.42 (LAPM) MNP5 MNP2-4 Wire	\N3 and %C1 (default)
V.42 and V.42bis only	\N4 and %C1
V.42 only	\N4 and %C0
MNP2-4 only	\N2 and %C0
MNP2-5 only	\N2 and %C1
No data compression and no error correction	\N0 and %C0

Table 2.0: Enabling Error Correction/Data Compression

2.3 Error Correction

The OEM-MODEM-xxC2 can employ error correction (reliable) protocols to ensure error-free delivery of asynchronous data sent between the host and the remote end. The error control methods are based on grouping data into frames with checksums determined by the contents of each frame. The receiving modem checks the frames and sends acknowledgments to the transmitting modem. When a faulty frame is detected, the receiving modem requests a retransmission. Frame length varies according to the amount of data transmitted or the number of retransmissions requested from the opposite end.

The OEM-MODEM-xxC2 supports V.42 and MNP2-4 error correction protocols. V.42 (LAPM) is most commonly used and is enabled in \N3 and \N4 modes. In the default mode (\N3), the modem attempts to connect with V.42 error correction and V.42bis data compression (OEM-MODEM-56C2/34C2/32C2) and falls back to either V.42 only, MNP 2-5, or no error correction (wire mode) if necessary. In \N4 mode, the OEM-MODEM-xxC2 hangs up if a V.42 connection cannot be established. If the modem hangs up in V.42 mode after all data is successfully sent, the result code is "OK". If the modem hangs up before all data is successfully sent, the result code is "No Carrier". If the modem connects without a protocol, "No Carrier" is always sent. The V.42 specification allows an alternate error correction protocol, MNP2-4. MNP2-4 is enabled in \N2 mode. In \N2 mode, the OEM-MODEM-xxC2 hangs up if an MNP2, 3, or 4 connection cannot be established.

2.4 Wire Mode

Wire mode is used to communicate with standard non-error correcting modems. When optioned with \N3, the OEM-MODEM-xxC2 falls back to wire mode if it fails in an attempt to negotiate a V.42 or MNP link with the remote modem. Error correction and data compression are not active in wire mode.

Filename	oem-modem-xxc2.doc	Document Revision	1.5
Date of Issue	18/02/2005	Page Number	11 of 61

2.5 Fast Connect

The OEM-MODEM-xxC2 supports several fast connect modes of operation to reduce the time of a connect sequence in originate mode.

2.5.1 V.29 Fast Connect

In addition to the low modulation speed fast connect modes, the OEM-MODEM-xxC2 also supports a fast connect mode based on the 9600 bps V.29 fax modulation standard. In order to provide a time-critical interface from the host to the modem, the modem uses an interface derived from the fax class 1 AT command set. The example below shows how the class 1 AT commands for V.29 would commonly be used in a client-side terminal (originating modem).

Calling Modem Example:

- AT+FCLASS=1

Set the modem in fax mode so that it can be switched back and forth between Data and Command mode after executing AT FAX commands.

- AT:U6C,2

Disable normal fax tone during handshaking indicating to answer modem that V.29 fast connect will be requested. Cause the execution of AT+FTM = 2 at the beginning of connection.

- ATDT1234567

Dial the number and wait for <CONNECT> and <OK> to establish connection.

- AT+FTM=2

(For reference only; there is no need to send this command to the modem) Transmit V.21(980 Hz) tone until Answer Tone(2100/ 2225 Hz) is received for 100 ms, followed by <OK>.

- AT = U6C,0

Restore U6C to default value.

- AT+FRM=96

Put modem in V.29 receiving mode. Wait for <CONNECT> and then receive data. Wait for <NO CARRIER>.

- AT+FTM=96

Set modem to V.29 transmit mode and wait for <CONNECT>. Send Data from DTE to DCE and wait for <OK> after sending <DLE><ETX> characters where DLE is a 0x10 character and ETX is a 0x03 character.

- AT+FRM=95

Set modem to V.29 short synchronous receiving mode. Wait for <CONNECT> and then receive data. Wait for <NO CARRIER> indicating transmission has ended.

- AT+FTM=95

Send out short synchronous signal and wait for <CONNECT>. Send Data from DTE to DCE and wait for <OK> after sending <DLE><ETX> characters.

- ATH

Hang up the modem.

Filename	oem-modem-xxc2.doc	Document Revision	1.5
Date of Issue	18/02/2005	Page Number	12 of 61

2.5.2 Transparent HDLC/Synchronous DCE Mode

The fast connect transparent HDLC modes are enabled via U7A and require Wire mode operation (\N0) refer to section 2.4. Each of the stages (answer tone detect time, unscrambled ones detect time, etc.) in the connect sequence may be shortened. The amount that each of these are shortened when in fast connect mode depends on the modulation (refer to table 2.1). The "transparent HDLC" mode of operation operates with an asynchronous DTE and a synchronous DCE. The OEM-MODEM-xxC2 performs HDLC frame packing and unpacking, frame opening and closing, flag generation and detection, CRC computation and checking, and 0 insertion and deletion. To use this mode, the DTE rate must be greater than the DCE rate; flow control via either CTS or /Q and /S must be used and Wire mode operation (\N0) is required (refer to table 2.2).

Protocol	DCE	Register Settings
All	Normal, Asynchronous	&Hn, \N0
V.22, Bell212, V.22bis	Normal, Transparent HDLC	&H6, 7, 8, \N0 U7A = 0002
Bell103, V.21	Fast connect, Asynchronous	&H9, 10, \N0 U7A = 0001
V.22, Bell212	Fast connect, Asynchronous	&H7, 8, \N0 U7A = 0001
V.22, Bell212	Fast connect, Transparent HDLC	&H7, 8, \N0 U7A = 0003
V.22bis	Transparent HDLC	&H6, \N0 U7A = 0002

Table 2.1: Fast Connect/Transparent HDLC

On the transmit side, if no data is received on TXD, the OEM-MODEM-xxC2 continually transmits HDLC flags at the DCE. As soon as there are 10 characters sent into the transmit buffer, the modem begins an HDLC frame at the DCE. The reason for this 10-character "head start" is to reduce the likelihood of an underrun once the HDLC frame has begun at the DCE. As long as the host continues to send data, the modem continues to zero insert, update the CRC value, and send data within an HDLC frame. To properly end the frame, the host must send a /Zn (see Table 2.2) indicating to the modem the end of the frame. Once the modem encounters the /Zn, it computes and sends the final CRC and begins transmitting HDLC flags. If an HDLC frame is smaller than the 10-character "head start", the HDLC frame is started at the DCE upon receipt of the /Zn character. The /Tn metacharacter is sent to the host to provide an indication that an HDLC frame was sent successfully. The "n" in the /Zn and /Tn is a single-byte, host-defined tag that can be used to track multiple HDLC frames.

To facilitate transmit flow control, the modem sends the /S and /Q metacharacters to the host. If the transmit buffer (512 bytes) is three quarters full, the /S metacharacter is sent to the host. The host must then stop transmitting. When the transmit buffer empties down to half full, the /Q metacharacter is sent to the host to indicate that it is okay to begin transmitting again. If a transmit underrun occurs, the current frame is aborted, and a /Un is sent to the host. All data from the underrun to the receipt of the /Zn metacharacter is discarded by the modem. A design goal of the host software should be to eliminate any occurrence of the /Un metacharacter.

Because the "/" is an escape character, the host must send a "/" when a "/" appears in the transmit data stream. The OEM-MODEM-xxC2 removes one "/" for each instance of "/" that appears on TXD.

Filename	oem-modem-xxc2.doc	Document Revision	1.5
Date of Issue	18/02/2005	Page Number	13 of 61

On the receive side, as long as HDLC flags are received by the OEM-MODEM-xxC2 at the DCE, it does not pass the data out RXD. Once the first non-flag word is detected, the modem performs zero deletion, calculates the CRC value, and passes the data out RXD. The modem continues in this manner until detecting the HDLC flags, which indicate the end of the frame. At this point, the HDLC frame is complete, and the modem calculates the final CRC and compares it to the CRC value received in the frame. If the CRC matches, the modem passes /G to the host. If the CRC does not match, the modem passes /B to the host to initiate a retransmit request.

Character*	Direction	Description
/Zn	TX	Follows the last character of a transmit frame. Once the frame has been sent, a /T metacharacter is sent to the host. <i>n</i> denotes a frame tag. <i>n</i> is echoed back later with the /U or /T metacharacters to make frame tracking easier.
//	TX	A forward slash character is to be transmitted.
/E	TX	Escape back to command mode. The modem returns to command mode.
/Un	RX	A transmit underrun has occurred, but a /Z metacharacter was not received. When an underrun occurs, the current frame is aborted; a /Un is sent to host, where <i>n</i> is the frame tag. All data following the underrun, up to the /Z metacharacter, is discarded by the modem.
/Tn	RX	The transmit frame, <i>n</i> , has been sent. The <i>n</i> from the /Z is echoed with the /Tn to allow tracking frames.
/G	RX	The previous receive frame CRC check was successful.
/B	RX	The previous receive frame CRC check was unsuccessful.
/S	RX	Transmit buffer is almost full; the host must pause transmission to prevent an overflow. If hardware flow control is used, the host may ignore this metacharacter.
/Q	RX	The host may begin transmitting again after a /S (pause) has been sent. If hardware flow control is used, the host may ignore this metacharacter.
//	RX	A forward slash character was received.
/A	RX	Receive frame aborted.
*Note: Characters after "/" must be uppercase.		

Table 2.2: Synchronous DCE Mode Metacharacters

Filename	oem-modem-xxc2.doc	Document Revision	1.5
Date of Issue	18/02/2005	Page Number	14 of 61

2.6 Intrusion Detection

The OEM-MODEM-xxC2 has the ability to detect when another telephone, modem, or other device is using the phone line. This allows the host to avoid interrupting another phone call when the phone line is already in use and to intelligently handle an interruption when the OEM-MODEM-xxC2 is using the phone line.

2.6.1 On-Hook Line-in-Use Detection

When the OEM-MODEM-xxC2 chipset is sharing the telephone line with other devices, it is important that it not interrupt a call in progress. To detect whether another device is using the shared telephone line, the host can use the modem to monitor the TIP-RING dc voltage with the LVCS (Line Voltage and Current Sense) register (U79, bits 4:0) as shown below. See also the %Vn commands for automatic line-in-use detection.

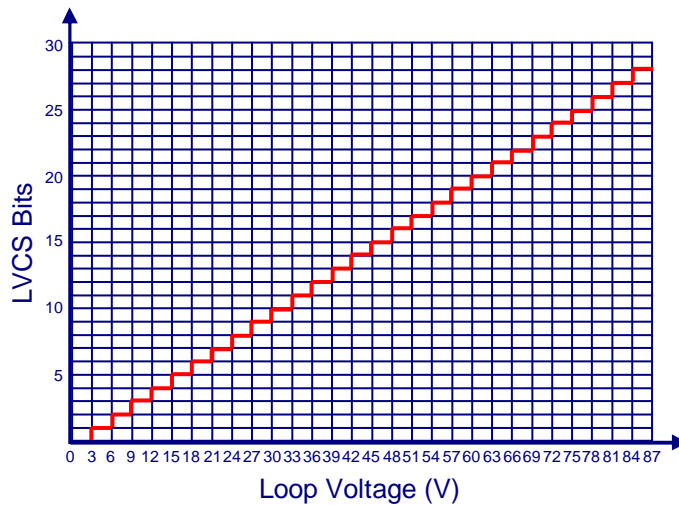

2.6.2 Off-Hook Intrusion Detection

When the OEM-MODEM-xxC2 is off-hook, an algorithm is implemented in the modem to automatically monitor the TIP-RING loop current via the LVCS register. When the modem is off-hook, the LVCS register switches from representing the TIP-RING voltage to representing the TIP-RING current as shown below. Upon detecting an intrusion, the modem may be configured to automatically hang up on a PPD interrupt by setting the HOI bit (U77, bit 11).

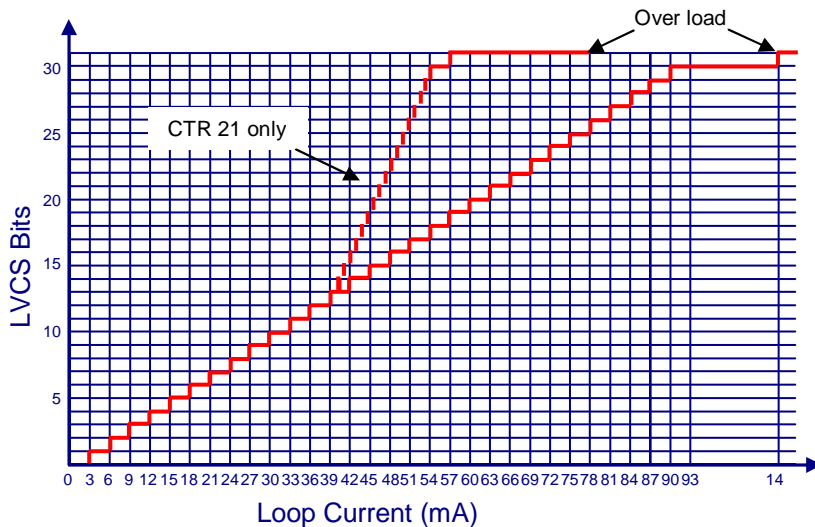

Filename	oem-modem-xxc2.doc	Document Revision	1.5
Date of Issue	18/02/2005	Page Number	15 of 61

2.7 Over Current Detection

The OEM-MODEM-xxC2 includes an over current detection feature that measures the loop current at a programmable time after the modem goes off-hook. This allows the modem to detect if it is connected to an improper telephone line. The over current detection feature is enabled by setting the OCDM bit (U70, bit 11). OHT (U77, bits 8:0) sets the delay after off-hook until the loop current is measured. In the CTR21 mode of operation, the over current detection can trip unnecessarily for loop current values greater than 55 mA. Therefore, if the OEM-MODEM-xxC2 is in CTR21 mode and an over current condition is detected, the host should switch the modem into FCC mode and check the LVCS register for a valid over current value equal to 0x1F.

2.8 Caller ID Operation

The OEM-MODEM-xxC2 supports full type 1 caller ID detection and decode for the US Bellcore, European ETSI, UK, and Japanese caller ID protocols. Caller ID is enabled via the +VCID and +VCDT commands.

2.9 Global Operation

The OEM-MODEM-xxC2 contains a programmable line interface to meet international telephone line interface requirements. The user-access registers (via the AT:U and AT:R commands) may be programmed for country specific settings, such as dial tone, ring, ring back, and busy tone. Please refer to “OEM-MODEM-xxC2 – Country Settings” application guide for more details.

2.10 Low Power Modes

Using the S24 S-register, the OEM-MODEM-xxC2 can be set to automatically enter sleep mode after a preprogrammed time of inactivity with either the DTE or the remote modem. The sleep mode is entered after (S24) seconds have passed since the TX FIFO has been empty. The modem remains in the sleep state until either a 1 to 0 transition on TXD (serial mode) occurs.

Additionally, the OEM-MODEM-xxC2 may be placed in a complete Power down mode. Complete power down is accomplished via U65[13] (PDN). Once the PDN bit is written, the modem completely powers down and can only be powered back on via the RESET pin.

2.11 Firmware Upgrades

The OEM-MODEM-xxC2 chipset contains an on-chip program ROM that includes the firmware required for the features listed in this data sheet. In addition, the modem contains on-chip program RAM to accommodate minor changes to the ROM firmware. This allows Comtech to provide future firmware updates to optimise the characteristics of new modem designs and those already deployed in the field.

2.12 EEPROM Interface

The OEM-MODEM-xxC2 provides non-volatile memory area used for custom default settings, firmware upgrades, and/or user-defined AT command macros for use in custom AT commands or country codes.

Filename	oem-modem-xxc2.doc	Document Revision	1.5
Date of Issue	18/02/2005	Page Number	16 of 61

3 AT Commands

At power up, the OEM-MODEM-xxC2 is in the AT Command mode. AT commands begin with the letters AT, end with a carriage return, and are case insensitive. However, case cannot be mixed in a single command. The only exception to this format is the A/ command. This command is neither preceded by AT nor followed by a carriage return but re-executes the previous command immediately when the "/" character is typed. Table 3.0 shows a summary of the AT commands set supported.

Table 3.0: AT Command Set Summary

Basic AT Command Set

Command	Description
\$	Display AT commands mode setting
A	Answer command
A/	Repeat last command
D	Dial command
E	Echo command
H	Hook control
I	Request ID information
M	Speaker operation
O	Return on-line to data mode
Q	Result code control
S	S-register operation
S\$	List contents of all S registers
V	Verbal Response Format
X	Call progress monitoring
Y	Long-space disconnect
Z	Hard reset
+VCID	Caller ID enable
+VCDT	Caller ID type
+FCLASS	Class 1 mode
+FTM	Class 1 transmit carrier
+FRM	Class 1 receive carrier
+GCI	Country settings

Extended AT% Command Set

Command	Description
%%\$	Display AT% command settings
%C	Data compression
%O	Answer mode
%V	Line status detection

Extended AT: Command Set

Command	Description
:E	EEPROM read
:I	Interrupt read
:M	EEPROM write
:P	Program RAM write
:R	User access register read
:U	User access register Write

Extended AT& Command Set

Command	Description
&\$	Display AT& command settings
&D	DTR mode
&G	Line connection rate limit
&H	Switch network handshake mode
&P	Japanese pulse dialling
&X	Determine telephone line type
&Z	Low-power mode

Extended AT\ Command Set

Command	Description
\\$	Display AT\ command settings
\B	Character length
\N	Asynchronous protocol
\P	Parity
\Q	Flow control
\T	DTE speed
\V	Connection message

3.1 AT Commands Reference

3.1.1 \$ Display AT command mode settings.

This commands displays the current command mode settings for echo command (E), speaker operation (M), result code control (Q), verbal result code (V), call progress monitoring (X) and long-space disconnect (Y), for example:

```

AT COMMAND SET
E=001      M=000      Q=000
V=001      X=004      Y=000
  
```

3.1.2 A Answer Command

This command instructs the modem to go off-hook and answer an incoming call.

3.1.3 A/ Repeat Last Command

This command repeats the last command string entered. Do not precede this command with an AT prefix or conclude it by pressing Enter.

3.1.4 Dn Dial Command

This command instructs the modem to begin the dialling sequence. The dial string (*n*, including modifiers and the telephone number) is entered after the ATD command. A dial string can be up to 40 characters long. Any digit or symbol (0-9, *, #, A, B, C, D) may be dialled as touch-tone digits. Characters such as spaces, hyphens, and parentheses do not count - they are ignored by the modem and may be included in the dial string to enhance readability. The following may be used as dial string modifiers:

Modifier	Function
G	Telephone voting mode. This modifier, intended for use in Japan, enables a special dial-in voting mode that may be used with certain automated voting systems. When this modifier is placed anywhere in the dial string (e.g. ATDG), the OEM-MODEM-xxC2 will dial the phone number and wait S7 seconds (60 by default) to detect a busy tone. When the busy tone is detected, the modem will report whether or not a polarity reversal occurs between the time the last digit is dialed and the detection of the busy tone. The modem will report either "POLARITY REVERSAL" or "NO POLARITY REVERSAL". It is not possible to establish a modem connection when using this command.
P	Pulse dialling.
T	Touch-tone dialling (default).
W	Wait for dial tone before continuing for S14 seconds (default: 12 seconds). Blind dialling modes X0, X1 and X3 do not affect the W command.
, or <	Pause during dialling. Pause for time specified in Register S8 before processing the next character in the dial string.
! or &	Flash hook switch for FHT (U4F) msec (default: 500 msec)
;	Return to command mode. Causes the modem to return to command mode after dialling the number, without disconnecting the call.

Filename	oem-modem-xxc2.doc	Document Revision	1.0
Date of Issue	18/02/2005	Page Number	18 of 61

3.1.5 *En* Echo Command

This command controls whether or not the characters entered from your computer keyboard are echoed back to your monitor while the modem is in command mode.

- E0. Disables echo to the DTE.
- E1. Enables echo to the DTE (default).

Result Codes:

OK $n = 0, 1$

ERROR Otherwise

3.1.6 *Hn* Hook Control

This command instructs the modem to go on-hook to disconnect a call, or off-hook to make the phone line busy.

- H0. Modem goes on-hook (default).
- H1. Modem goes off-hook.

Result Codes:

OK $n = 0, 1$

ERROR Otherwise

3.1.7 *In* Request ID Information

This command displays specific product information about the modem.

- I0. Display data pump revision code:

- B: Revision B
 - C: Revision C

- I1. Display data pump firmware revision code (numeric)
- I3. Display line-side revision code
- I4. Display the data pump model number.
- I7. Diagnostic Results 1
- I8. Diagnostic Results 2

Result Codes:

OK $n = 0, 1, 3, 4, 7, 8$

ERROR Otherwise

Filename	oem-modem-xxc2.doc	Document Revision	1.0
Date of Issue	18/02/2005	Page Number	19 of 61

3.1.8 Mn Speaker operation

This command is used to configure the loudspeaker operation. Although the all OEM-MODEM-xxC2 hardware support a loudspeaker, due to space restrictions, this feature is not supported on standard boards.

- M0. Speaker is always off.
- M1. Speaker is on while dialling and handshaking; off in data mode.
- M2. Speaker is always on.
- M3. Speaker is off while dialling, on during handshaking and retraining.

Result Codes:

OK $n = 0, 1, 2, 3$

ERROR Otherwise

3.1.9 On Return On-line to Data Mode

This command is return to data mode after escaping to command mode. Refer to section 2.1.3 on escaping methods.

- O0. Return to data mode.
- O1. Return to data mode and perform retrain full retrain
- O2. Return to data mode and perform rate renegotiation.

Result Codes:

OK $n = 0, 1, 2$

ERROR Otherwise

3.1.10 Qn Result Code Control

Result codes are informational messages sent from the modem. Basic result codes are OK, CONNECT, RING, NO CARRIER, and ERROR. The ATQ command allows the user to turn result codes on or off.

- Q0. Enables modem to send result codes to the computer (default).
- Q1. Disables modem from sending result codes to the computer.

Result Codes:

OK $n = 0, 1$

ERROR Otherwise

Filename	oem-modem-xxc2.doc	Document Revision	1.0
Date of Issue	18/02/2005	Page Number	20 of 61

3.1.11 Vn Verbal Response Format

This command controls whether result codes (including call progress and negotiation progress messages) are displayed as words or their numeric equivalents.

- V0. Displays result codes as digits.
- V1. Displays result codes as text (default).

Result Codes:

OK $n = 0, 1$

ERROR Otherwise

3.1.12 Xn Call Progress Monitoring

This command controls the call progress monitoring (CPM) performed during a connection (refer to table 3.1).

- X0. Basic results; disable CPM—Blind dial (does not wait for dial tone). CONNECT message does not include speed.
- X1. Extended results; disable CPM—Blind dial. CONNECT message includes speed.
- X2. Extended results and detect dial tone only—Add dial tone detection to X1 mode. Does not blind dial.
- X3. Extended results and detect busy only—Add busy tone detection to X1 mode.
- X4. Extended results full CPM—Full CPM enabled CONNECT message includes speed.
- X5. Extended results—Full CPM enabled including ring back detection. Adds ring back detection to X4 mode.

Result Codes:

OK $n = 0, 1, 2, 3, 4, 5$

ERROR Otherwise

3.1.13 Yn Long Space Disconnect

Long space disconnect—Modem will hang up after 1.5 seconds or more of continuous space while on-line.

- Y0. Disable long space disconnect (default).
- Y1. Enable long space disconnect.

Result Codes:

OK $n = 0, 1$

ERROR Otherwise

3.1.14 Z Hard Reset

This command is functionally equivalent to pulsing the RESET pin low.

No Result Codes

Filename	oem-modem-xxc2.doc	Document Revision	1.0
Date of Issue	18/02/2005	Page Number	21 of 61

3.1.15 +VCID=*n* Caller ID Control.

This command controls Caller ID and whether the CID data is formatted before display.

- +VCID=0. Caller ID disabled
- +VCID=1. Caller ID enabled—data formatted
- +VCID=2. Caller ID enabled—raw data format

Result Codes:

OK *n* = 0, 1, 2

ERROR Otherwise

3.1.16 +VCDT=*n* Caller ID Type.

This command selects which Caller ID standard is supported.

- +VCDT=0. After ring only
- +VCDT=1. Always on
- +VCDT=2. UK
- +VCDT=3. Japan
- +VCDT=4. DTMF

Result Codes:

OK *n* = 1, 2, 3, 4

ERROR Otherwise

3.1.17 +FCLASS=*n* Class 1 Modem Enabled.

This command controls Class 1 mode for use in the V.29 Fast Connect mode. For more information refer to section 2.5.1.

- +FCLASS=0. Class 1 mode disabled
- +FCLASS=1. Class 1 mode enabled

Result Codes:

OK *n* = 0, 1

ERROR Otherwise

Filename	oem-modem-xxc2.doc	Document Revision	1.0
Date of Issue	18/02/2005	Page Number	22 of 61

3.1.18 +FTM=*n* Class 1 Transmit Carrier.

This command controls Class 1 Transmit Carrier. For more information refer to section 2.5.1.

- +FTM=2. Transmit V.21 (980 Hz) tone and detect (2100/2225 Hz) tone. Stop transmit 980 Hz when 2100/2225 detected. Class 1 mode disabled
- +FTM=53. Same as &T4, but transmit V.29 7200 bps. Data pattern set by S40 register. AT+FCLASS = 0 must be sent to restore the modem to normal operation after test.
- +FTM=54. Same as &T4, but transmit V.29 9600 bps. Data pattern set by S40 register. AT+FCLASS = 0 must be sent to restore the modem to normal operation after test.
- +FTM=95. V.29 short synchronous.
- +FTM=96. V.29 full synchronous.

Result Codes:

OK *n* = 2, 53, 54, 95, 96

ERROR Otherwise

3.1.19 +FRM=*n* Class 1 Receive Carrier.

This command controls Class 1 Receive Carrier. For more information refer to section 2.5.1.

- +FRM=2. Detect V.21 (980 Hz) tone for longer than 100 ms, then send answer tone (2100/2225 Hz) for 200 ms.
- +FRM=95. V.29 short synchronous.
- +FRM=96. V.29 full synchronous.

Result Codes:

OK *n* = 2, 95, 96

ERROR Otherwise

3.1.20 +GCI=*n* Country Settings

This command automatically configures all registers for a specific country. Changes may be made by writing individual registers after sending the AT+GCI command. Several countries use the same configurations as the United Kingdom and the United States. For more details please refer to "OEM-MODEM-xxC(2): Country Settings" application guide.

- +GCI=0. Japan
- +GCI=B4. United Kingdom
- +GCI=B5. United States

Result Codes:

OK *n* = refer "OEM-MODEM-xxC(2): Country Settings" application guide.

ERROR Otherwise

Filename	oem-modem-xxc2.doc	Document Revision	1.0
Date of Issue	18/02/2005	Page Number	23 of 61

3.1.21 %\$ Display AT% command settings.

This command displays the current data compression (%C), auto-answer modes (%O) and line status detection (%V). For example:

```

AT COMMAND SET
%C=001 %O=001 %V=000

```

3.1.22 %Cn Data compression

This command determines the whether error control is used by the modem when sending or receiving data.

- %C0. Disable V.42bis data compression
- %C1. Enable V.42bis in transmit and receive paths (default). If MNP is selected (\N2 or \N3), then %C1 enables MNP5 in transmit and receive paths.
- %C2. Enable V.42bis in transmit path only
- %C3. Enable V.42bis in receive path only

Result Codes:

OK $n = 0, 1, 2, 3$

ERROR Otherwise

3.1.23 %On Answer mode

This command determines the whether error control is used by the modem when sending or receiving data.

- %O1. Modem will auto-answer a call in answer mode
- %O2. Modem will auto-answer a call in originate mode

Result Codes:

OK $n = 1,2$

ERROR Otherwise

3.1.24 %Vn Automatic Line Status Detection.

After the %V1 and %V2 commands are issued, the OEM-MODEM-xxC will automatically check the telephone connection for whether or not a line is present. If a line is present, the modem will automatically check if the line is already in use. Finally, the modem will check line status both before going off-hook and again before dialling. %V1 uses the fixed method and %V2 uses the adaptive method. %V0 (default) disables this feature.

Filename	oem-modem-xxc2.doc	Document Revision	1.0
Date of Issue	18/02/2005	Page Number	24 of 61

%V0. Disable automatic line-in-use detection.

%V1 Automatic Line Status Detection - Fixed Method.

Description: Before going off-hook with the ATD, ATO, or ATA commands, the modem compares the line voltage (via LVCS) to registers NOLN (U83) and LIUS (U84):

Loop Voltage	Action
$0 \leq LVCS \leq NOLN$	Report "NO LINE" and remain on-hook.
$NOLN \leq LVCS \leq LIUS$	Report "LINE IN USE" and remain on-hook.
$LIUS \leq LCVS$	Go off-hook and establish a modem connection.

Once the call has begun, the off-hook intrusion algorithm operates normally. In addition, the OEM-MODEM-xxC will report "NO LINE" if the telephone line is completely disconnected. If the HOI bit (U77, bit 11) is set, "LINE IN USE" is reported upon intrusion.

%V2. Automatic Line Status Detection - Adaptive Method.

Description: Before going off-hook with the ATD, ATO, or ATA commands, the modem compares the line voltage (via LVCS) to the NLIU (U85) register:

Loop Voltage	Action
$0 \leq LVCS \leq (0.0625 \times NLIU)$	Report "NO LINE" and remain on-hook.
$(0.0625 \times NLIU) < LVCS \leq (0.85 \times NLIU)$	Report "LINE IN USE" and remain on-hook.
$(0.85 \times NLIU) < LCVS$	Go off-hook and establish a modem connection.

The NLIU register is updated every 1 ms with the minimum non-zero value of LVCS in the last 30 ms. This allows the OEM-MODEM-xxC to eliminate errors due to 50/60 Hz interference and also adapt to relatively slow change in the on-hook dc reference value on the telephone line. This algorithm does not allow any non-zero values for NLIU below 0x0007. The host may also initialize NLIU prior to issuing the %V2 command. Once the call has begun, the off-hook intrusion algorithm operates normally. In addition, the modem will report "NO LINE" if the telephone line is completely disconnected. If the HOI (U77, bit 11) bit is set, "LINE IN USE" is reported upon intrusion.

Result Codes:

OK $n = 0, 1, 2$

ERROR Otherwise

Filename	oem-modem-xxc2.doc	Document Revision	1.0
Date of Issue	18/02/2005	Page Number	25 of 61

3.1.25 :E EEPROM Read

This command is used to read data from non-volatile area of memory. For more details please refer to “OEM-MODEM-xxC2: Using Non-Volatile Memory” application guide.

The format for this command is:

AT:Eaaaa

Where: aaaa is the first non-volatile address in hexadecimal

Result Codes:

The hexadecimal contents of non-volatile address specified

3.1.26 :I Interrupt Read

This command causes the OEM-MODEM-xxC2 to display the lower 8 bits of the interrupt register I/O Control 0 (U70). The RST, CID, OCD, PPD and RI bits will also be cleared and the INT pin (INT bit in parallel mode) will be deactivated on this read.

Result Codes:

Hex value of the interrupt register I/O lower 8 bits.

3.1.27 :M EEPROM Write

This command allows the user to place data into the non-volatile area of memory. For more details please refer to “OEM-MODEM-xxC2: Using Non-Volatile Memory” application guide. The format for this command is:

AT:Maaaa,y0,y1,y2,y3,y4,y5,y6,y7

Where: aaaa is the first address in hexadecimal
 Y0-y7 is the data in hexadecimal written into EEPROM.

No more than eight bytes can be written into the EEPROM at one time.

Result Codes:

OK

Filename	oem-modem-xxc2.doc	Document Revision	1.0
Date of Issue	18/02/2005	Page Number	26 of 61

3.1.28 :P Program RAM Write

This command is used to upload firmware supplied by Comtech to the datapump. The format for this command is

AT:Paaaa,xxxx,yyyy,...

Where: aaaa is the first address in hexadecimal
 xxxx,yyyy is the data in hexadecimal.

Only one :P command is allowed per AT command line. No other commands can be concatenated in the :P command line. This command is **only** for use with authorised patches provided by Comtech. Do not attempt to use this command for any other purpose.

Result Codes:

OK

3.1.29 :R User-Access Register Read

This command allows the user to read from the user-access registers. (See page ??). The format is:

AT:Raa where aa = user-access address in hexadecimal.

Result Codes:

The hexadecimal contents of the specified U- register.

3.1.30 :U User-Access Register Write

This command allows the user to write to the 16-bit user-access registers. (See page ??). The format is:

AT:Uaa,xxxx,yyyy,zzzz,...

Where: aa is the user-access address in hexadecimal.
 xxxx is the data in hexadecimal to be written to location aa.
 yyyy is the data in hexadecimal to be written to location (aa + 1).
 zzzz is the data in hexadecimal to be written to location (aa + 2).

Result Codes:

OK

Filename	oem-modem-xxc2.doc	Document Revision	1.0
Date of Issue	18/02/2005	Page Number	27 of 61

3.1.31 &\$ Display AT& current settings.

This command displays the current AT& command settings for DTR mode (&D), line connection rate limit (&G) and switched network handshake mode (&H). For example:

```
AT COMMAND SET
&D=001      &G=017      &H=000
```

3.1.32 &Dn DTR Mode

This command determines what action (if any) DTR has when in data mode

```
&D0 Not used
&D1 Escape to command mode if also enabled by HES U70, bit 15.
&D2 Disconnect call and return to command mode.
&D3 Reset (ATZ)
```

Result Codes:

OK $n = 0, 1, 2, 3$

ERROR Otherwise

3.1.33 &Gn Line connection rate limit

This command sets an upper limit on the line speed that the modem can connect. Note that the &Hn commands may limit the line speed as well (&Gn not used for &H0 or &H1). Not all modulations support rates given by &G. Any improper setting will be ignored.

```
&G5. 4.8 kbps max
&G6. 7.2 kbps max
&G7. 9.6 kbps max
&G8. 12 kbps max
&G9. 14.4 kbps max1
&G10. 16.8 kbps max
&G11. 19.2 kbps max
&G12. 21.6 kbps max
&G13. 24.0 kbps max
&G14. 26.4 kbps max
&G15. 28.8 kbps max
&G16. 31.2 kbps max
&G17. 33.6 kbps max2
```

1. Default for the OEM-MODEM-32C2
2. Default for the OEM-MODEM-56C2/34C2

Result Codes:

OK $n = 5-17$

ERROR Otherwise

Filename	oem-modem-xxc2.doc	Document Revision	1.0
Date of Issue	18/02/2005	Page Number	28 of 61

3.1.34 &Hn Switched network handshake mode

This command sets a limit on the line speed that the modem can connect. Note that the &Hn commands may limit the line speed as well (not used for &H0 or &H1).

&H0.	V.90 with automatic fallback (56 kbps to 300 bps) ¹
&H1.	V.90 only (56 kbps to 28 kbps)
&H2.	V.34 with automatic fallback (33.6 kbps to 300 bps) ²
&H3.	V.34 only (33.6 kbps to 2400 bps)
&H4.	ITU-T V.32bis with automatic fallback (14.4 kbps to 300 bps) ³
&H5.	ITU-T V.32bis only (14.4 kbps to 4800 bps)
&H6.	ITU-T V.22bis only (2400 kbps or 1200 bps) ⁴
&H7.	ITU-T V.22 only (1200 bps)
&H8.	Bell 212 only (1200 bps)
&H9.	Bell 103 only (300 bps)
&H10.	ITU-T V.21 only (300 bps)
&H11.	V.23 1200/75 bps

1. Default for the OEM-MODEM-56C2
2. Default for the OEM-MODEM-34C2
3. Default for the OEM-MODEM-32C2
4. Default for the OEM-MODEM-24C2

Result Codes:

OK *n* = 0-11

ERROR Otherwise

3.1.35 &Z low-power mode.

This command places the line side into low-power reducing the current consumption to typically 3mA. The line side will wake-on-ring or an AT instruction.

Result Code:

OK

Filename	oem-modem-xxc2.doc	Document Revision	1.0
Date of Issue	18/02/2005	Page Number	29 of 61

3.1.36 \\$ Display AT\ command settings.

This command displays the current local serial settings: character length (\B), asynchronous protocol (\N), parity type (\P), flow control (\Q), DTE speed (\T) and connection message (\V). For example:

```

AT COMMAND SET
  \B=003      \N=003      \P=000
  \Q=003      \T=016      \V=000
  
```

3.1.37 \Bn Character length

This command set the DTE character length. The Character length will be automatically set in autobaud mode.

- \B0. 6N1: 6 data bits, no parity, 1 stop bit, 1 start bit, 8 bits total (\N0 only)
- \B1. 7N1: 7 data bits, no parity, 1 stop bit, 1 start bit, 9 bits total (\N0 only)
- \B2. 7P1: 7 data bits, parity optioned by \P, 1 stop bit, 1 start bit, 10 bits total
- \B3. 8N1: 8 data bits, no parity, 1 stop bit, 1 start bit, 10 bits total (default)
- \B5. 8P1: 8 data bits, parity optioned by \P, 1 stop bit, 1 start bit, 11 bits total (\N0 only)
- \B6. 8X1: 8 data bits, 1 escape bit, 1 stop bit, 1 start bit, 11 bits total (enables 9th-bit)

OK $n = 0-3, 5, 6$

ERROR Otherwise

3.1.38 \Nn Asynchronous protocol

This command set the Asynchronous protocol used.

- \N0. Wire mode (no error correction, no compression)
- \N2. MNP reliable mode. The modem attempts to connect with the MNP protocol. If unsuccessful, the call is dropped.
- \N3. V.42 auto-reliable—The modem will try to connect with data compression and error correction (V42bis and V.42). If unsuccessful, V.42 only is attempted. If unsuccessful, wire mode is attempted (default).
- \N4. V.42 (LAPM) reliable mode (or drop call)—Same as \N3 except that the modem will drop the call instead of connecting in wire mode.
- \N5. V.42 and MNP reliable mode - The modem attempts to connect with V.42. If unsuccessful, MNP is attempted. If MNP is unsuccessful, the call is dropped.

OK $n = 0, 2, 3, 4, 5$

ERROR Otherwise

Filename	oem-modem-xxc2.doc	Document Revision	1.0
Date of Issue	18/02/2005	Page Number	30 of 61

3.1.39 \Pn Parity type

This command set the DTE parity type. Parity type will be automatically set in autobaud mode.

- \P0. Even (default)
- \P1. Space
- \P2. Odd
- \P3. Mark

OK $n = 0-3$

ERROR Otherwise

3.1.40 \Qn Modem-to-DTE flow control

This command set the Modem-to-DTE flow control used,

- \Q0. Disable all flow control—Note that this may only be used if the DTE speed and the VF speed are guaranteed to match throughout the call.
- \Q2. Use CTS only (default)
- \Q3. Use RTS/CTS
- \Q4. Use XON/XOFF flow control for modem-to-DTE interface. Does not enable modem-to-modem flow control.

OK $n = 0, 2-4$

ERROR Otherwise

3.1.41 \Tn DTE speed

This command sets the bit rate between the modem and DTE. When changing rates, the result code "OK" is sent at the old DTE rate. All options except \T16 lock the DTE to the given rate. When \T16 is used, automatic bandrate detection is used for subsequent commands.

- \T0. 300 bps
- \T1. 600 bps
- \T2. 1200 bps
- \T3. 2400 bps
- \T4. 4800 bps
- \T5. 7200 bps
- \T6. 9600 bps
- \T7. 12.0 kbps
- \T8. 14.4 kbps
- \T9. 19.2 kbps
- \T10. 38.4 kbps
- \T11. 57.6 kbps
- \T12. 115.2 kbps
- \T13. 230.4 kbps
- \T14. 245.760 kbps
- \T15. 307.200 kbps
- \T16. Autobaud on (default)
- \T17. Autobaud off; lock at current baud rate.

OK $n = 0-15$

ERROR Otherwise

Filename	oem-modem-xxc2.doc	Document Revision	1.0
Date of Issue	18/02/2005	Page Number	31 of 61

3.1.42 \Vn Connect message type

This command configures the connection message type.

- \V0. Report connect message and protocol message (default)
- \V2. Report connect message only (exclude protocol message)
- \V4. Report connect and protocol message with both upstream and downstream connect rates.

OK $n = 0,1$

ERROR Otherwise

Filename	oem-modem-xxc2.doc	Document Revision	1.0
Date of Issue	18/02/2005	Page Number	32 of 61

Numeric ¹	Meaning	Verbal Response	X0	X1	X2	X3	X4	X5
0	Command was successful	OK	X	X	X	X	X	X
1	Link established at 300 bps or higher	CONNECT	X	X	X	X	X	X
2	Incoming ring detected	RING	X	X	X	X	X	X
3	Link dropped	NO CARRIER	X	X	X	X	X	X
4	Command failed	ERROR	X	X	X	X	X	X
5	Link establish at 1200	CONNECT 1200		X	X		X	X
6	Dial tone not present	NO DIALTONE			X		X	X
7	Line busy	BUSY				X	X	X
8	Remote not answering	NO ANSWER	X	X	X	X	X	X
9	Ringback detected	RINGING						X
10	Link established at 2400	CONNECT 2400		X	X	X	X	X
11	Link established at 4800	CONNECT 4800		X	X	X	X	X
12	Link established at 9600	CONNECT 9600		X	X	X	X	X
14	Link established at 19200	CONNECT 19200 ²		X	X	X	X	X
15	Link established at 7200	CONNECT 7200		X	X	X	X	X
16	Link established at 12000	CONNECT 12000		X	X	X	X	X
17	Link established at 14400	CONNECT 14400		X	X	X	X	X
18	Link established at 16800	CONNECT 16800 ²		X	X	X	X	X
19	Link established at 21600	CONNECT 21600 ²		X	X	X	X	X
20	Link established at 24000	CONNECT 24000 ²		X	X	X	X	X
21	Link established at 26400	CONNECT 26400 ²		X	X	X	X	X
22	Link established at 28800	CONNECT 28800 ²		X	X	X	X	X
23	Link established at 31200	CONNECT 31200 ²		X	X	X	X	X
24	Link established at 33600	CONNECT 33600 ²		X	X	X	X	X
30	Caller ID mark detected	CIDM	X	X	X	X	X	X
75	Link established at 75	CONNECT 75		X	X	X	X	X
31	Hookswitch flash detected	FLASH	X	X	X	X	X	X
32	UK CID State Tone Alert Signal detected	STAS	X	X	X	X	X	X
33	Overcurrent condition	X ³	x	X	X	X	X	X
40	Blacklist is full	BLACKLIST FULL (enabled via S42 register)	X	X	X	X	X	X
41	Attempted number is blacklisted	BLACKLISTED (enabled via S42 register)	X	X	X	X	X	X
42	No phone line present	NO LINE (enabled via %Vn commands)	X	X	X	X	X	X
43	Telephone line is in use	LINE IN USE (enabled via %Vn commands)	X	X	X	X	X	X
44	A polarity reversal was detected	POLARITY REVERSAL (enabled via G modifier)	X	X	X	X	X	X
45	A polarity reversal was NOT detected	NO POLARITY REVERSAL (enabled via G modifier)	X	X	X	X	X	X

Notes:

- Numeric result codes are of the format: Result code <CR>.
- This message is only supported on the OEM-MODEM-56C2 and OEM-MODEM-34C2
- X is the only verbal response code that does not follow the <CR><LF>Result Code<CR><LF> standard. There is no leading <CR><LF>.
- This message is only supported on the OEM-MODEM-56C2

Table 3.1: Result Codes

Filename	oem-modem-xxc2.doc	Document Revision	1.0
Date of Issue	18/02/2005	Page Number	33 of 61

Numeric1	Meaning	Verbal Response	X0	X1	X2	X3	X4	X5
52	Link established at 56000	CONNECT 56000 ⁴		X	X	X	X	X
60	Link established at 32000	CONNECT 32000 ⁴		X	X	X	X	X
61	Link established at 48000	CONNECT 48000 ⁴		X	X	X	X	X
63	Link established at 28000	CONNECT 28000 ⁴		X	X	X	X	X
64	Link established at 29333	CONNECT 29333 ⁴		X	X	X	X	X
65	Link established at 30666	CONNECT 30666 ⁴		X	X	X	X	X
66	Link established at 33333	CONNECT 33333 ⁴		X	X	X	X	X
67	Link established at 34666	CONNECT 34666 ⁴		X	X	X	X	X
68	Link established at 36000	CONNECT 36000 ⁴		X	X	X	X	X
69	Link established at 37333	CONNECT 37333 ⁴		X	X	X	X	X
70	No protocol	PROTOCOL: NONE	Set with \V command.					
77	V.42 protocol	PROTOCOL: V42	Set with \V command.					
79	V.42bis protocol	PROTOCOL: V42bis	Set with \V command.					
80	MNP2 protocol	PROTOCOL: ALTERNATE + CLASS 2	Set with \V command.					
81	MNP3 protocol	PROTOCOL: ALTERNATE + CLASS 3	Set with \V command.					
82	MNP4 protocol	PROTOCOL: ALTERNATE + CLASS 4	Set with \V command.					
83	MNP5 protocol	PROTOCOL: ALTERNATE + CLASS 5	Set with \V command.					
90	Link established at 38666	CONNECT 38666 ⁴		X	X	X	X	X
91	Link established at 40000	CONNECT 40000 ⁴		X	X	X	X	X
92	Link established at 41333	CONNECT 41333 ⁴		X	X	X	X	X
93	Link established at 42666	CONNECT 42666 ⁴		X	X	X	X	X
94	Link established at 44000	CONNECT 44000 ⁴		X	X	X	X	X
95	Link established at 45333	CONNECT 45333 ⁴		X	X	X	X	X
96	Link established at 46666	CONNECT 46666 ⁴		X	X	X	X	X
97	Link established at 49333	CONNECT 49333 ⁴		X	X	X	X	X
98	Link established at 50666	CONNECT 50666 ⁴		X	X	X	X	X
99	Link established at 52000	CONNECT 52000 ⁴		X	X	X	X	X
100	Link established at 53333	CONNECT 53333 ⁴		X	X	X	X	X
101	Link established at 54666	CONNECT 54666 ⁴		X	X	X	X	X
102	DTMF dial attempt on a pulse dial only line		X	X	X	X	X	X
Notes:								
1. Numeric result codes are of the format: Result code <CR>.								
2. This message is only supported on the OEM-MODEM-56C2 and OEM-MODEM-34C2								
3. X is the only verbal response code that does not follow the <CR><LF>Result Code<CR><LF> standard. There is no leading <CR><LF>.								
4. This message is only supported on the OEM-MODEM-56C2								

Table 3.1: Result Codes (continued)

Filename	oem-modem-xxc2.doc	Document Revision	1.0
Date of Issue	18/02/2005	Page Number	34 of 61

4 S-Registers

The S command allows reading (Sn?) or writing (Sn=x) the S-registers. The S-registers store values for functions that typically are rarely changed, such as timers or counters, and the ASCII values of control characters, such as carriage return. Table 3.2 summarizes the S-register set.

Register	Default	Units	Description
S0	0	Rings	Automatic answer ring number
S1	0	Rings	Ring counter
S2	43	ASCII	AT escape character
S3	13	ASCII	Command line termination character
S4	10	ASCII	Response formatting character
S5	8	ASCII	Command line editing character
S6	2	Seconds	Wait before dialling
S7	50	Seconds	Connection completion time-out
S8	2	Seconds	Comma dial modifier time
S9	6	0.1 Sec	Carrier presence timer
S10	20	0.1 Sec	Automatic disconnect delay
S12	50	0.02 Sec	Escape guard time
S14	12	Seconds	Wait for dial tone delay value
S24	0	Seconds	Sleep inactivity time
S30	0	Seconds	Disconnect inactivity timer
S38	1	Seconds	Hang up delay timer
S40	0	-	Data pattern
S41	0	-	V34 symbol rate
S42	0	-	Blacklisting
S43	-	-	Dial attempts to blacklist
S44	-	Seconds	Blacklist Timer
S50	3	Seconds	Minimum on-hook time
S51	1	-	Number to start checking for an outside line on a PBX.

Table 3.2. The S-Register Summary

Filename	oem-modem-xxc2.doc	Document Revision	1.0
Date of Issue	18/02/2005	Page Number	35 of 61

4.1 S-Registers Reference

S-registers generally affect how AT commands perform. Contents of the registers can be displayed or modified when the modem is in command mode.

To display the value of an S-register:

```

TYPE      ATSn?   where n is the register number.
PRESS     Enter
  
```

To modify the value of an S-register:

```

TYPE      ATSn = r  where n is the register number, and r is the new register value.
PRESS     Enter
  
```

4.1.1 S0 Auto Answer Ring Number

This register determines the number of rings the modem will count before automatically answering a call. Enter 0 (zero) if you do not want the modem to automatically answer at all. When disabled, the modem can only answer with an ATA command.

Range: 0—255

Default: 0

Units: rings

4.1.2 S1 Ring Counter

This is the ring counter register and is read only. The value of S1 is incremented with each ring. If no rings occur over a six second interval, this register is cleared.

Range: 0—255

Default: 0

Units: rings

4.1.3 S2 AT Escape Character (User Defined)

This register determines the ASCII valued used for an escape sequence. The default is the + character. The escape sequence allows the modem to exit data mode and enter command mode when on-line. Values greater than 127 disable the escape sequence.

Range: 0—255

Default: 43

Units: ASCII

Filename	oem-modem-xxc2.doc	Document Revision	1.0
Date of Issue	18/02/2005	Page Number	36 of 61

S3 Command Line Termination Character (User Defined)

This register determines the ASCII values as the carriage return character. This character is used to end command lines and result codes.

Range: 0—255, ASCII decimal

Default: 13 (carriage return)

Units: ASCII

4.1.4 S4 Response Formatting Character (User Defined)

This register determines the ASCII value used as the line feed character. The modem uses a line feed character in command mode when it responds to the computer.

Range: 0—255, ASCII decimal

Default: 10 (line feed)

Units: ASCII

4.1.5 S5 Command Line Editing Character (User Defined)

This register sets the character recognised as a backspace. This character can be used to edit a command line.

Range: 0—255

Default: 8 (backspace)

Units: ASCII

4.1.6 S6 Wait Before Dialling

This register sets the length of time, in seconds, that the modem must wait (pause) after going off-hook before dialling the first digit of the telephone number. This operation is only applicable if blind dialling is enabled (X0, X1, X3).

Range: 0—255

Default: 2

Units: seconds

Filename	oem-modem-xxc2.doc	Document Revision	1.0
Date of Issue	18/02/2005	Page Number	37 of 61

4.1.7 S7 Connection Completion Time-Out

This register sets the time, in seconds, that the modem must wait before hanging up because carrier is not detected. This register also sets the number of seconds the modem will wait for ringback when originating a call before hanging up.

Range: 0—255

Default: 60

Units: seconds

4.1.8 S8 Comma Dial Modifier Time

This register sets the time, in seconds, that the modem must pause when it encounters a comma (,) in the dial command string.

Range: 0—255

Default: 2

Units: seconds

4.1.9 S9 Carrier Presence Timer

This register sets the length of time, in tenths of a second, that the modem must detect the carrier (after a loss of carrier) before reactivating DCD. S9 is referred to as “carrier loss debounce time.”

Range: 1—255

Default: 6

Units: 0.1 seconds

4.1.10 S10 Automatic Disconnect Delay

This register sets the length of time, in tenths of a second, that the modem waits before hanging up after a loss of carrier. This allows for a temporary carrier loss without causing the local modem to disconnect. The actual interval the modem waits before disconnecting is the value in register S10.

Range: 1—255

Default: 14

Units: 0.1 seconds

Filename	oem-modem-xxc2.doc	Document Revision	1.0
Date of Issue	18/02/2005	Page Number	38 of 61

4.1.11 S12 Escape Guard Time

This register sets the value (in 20 ms increments) for the required pause after the escape sequence (default 1 s).

Range: 1—255

Default: 50

Units: 0.02 seconds

4.1.12 S14 Dial Tone Detection Time

This register sets the time to wait for dial tone in relation to the *W* dial modifier. The timing starts when “W” is executed in the dial string.

Range: 0—255

Default: 12

Units: seconds

4.1.13 S24 Sleep Inactivity Time

This register sets the time that the modem will operate in normal power mode with no activity on the serial port or telephone line before entering low-power sleep mode. This feature is disabled if the timer is set to 0.

Range: 0—255

Default: 0

Units: seconds

4.1.14 S30 Inactivity Timer

S30 specifies the length of time (in minutes) that the modem will wait before disconnecting when no data is sent or received. This function is only applicable to buffer mode.

Range: 0—255

Default: 0

Units: minutes

Filename	oem-modem-xxc2.doc	Document Revision	1.0
Date of Issue	18/02/2005	Page Number	39 of 61

4.1.15 S38 Hang Up Delay Timer

This register sets the maximum delay between receipt of ATH0 command and hang up. If time out occurs before all data can be sent, the NO CARRIER (3) result code is sent (operates in V.42 mode only). "OK" response is sent if all data is transmitted prior to timeout. S38 = 255 disables timeout and modem will only disconnect if data is successfully sent or carrier is lost.

Range: 0—255

Default: 20

Units: seconds

4.1.16 S40 Data Pattern

This register sets the data pattern generated during &T4 and &T5 transmit tests.

- 0 – All spaces (0s)
- 1 – All marks (1s)
- 2 – Random data

Range: 0—2

Default: 0

Units: None

4.1.17 S41 V.34 Symbol Rate

This register sets the symbol rate for V.34 when using the &T4 and &T5 commands.

- 0 – 2400 symbols/second**
- 1 – 2743 symbols/second
- 2 – 2800 symbols/second
- 3 – 3000 symbols/second
- 4 – 3200 symbols/second
- 5 – 3429 symbols/second

A valid combination of symbol rate (S41) and data rate (&G) must be selected.

Symbol Rate	Allowable Data Rates
2400	2400 – 21600
2743	4800 – 26400
2800	4800 – 26400
3000	4800 – 28800
3200	4800 – 31200
3429	4800 – 33600

Range: 0—5

Default: 0

Units: None

Filename	oem-modem-xxc2.doc	Document Revision	1.0
Date of Issue	18/02/2005	Page Number	40 of 61

S42 Blacklisting

Blacklisting - The OEM-MODEM-xxC2 will not dial the same number more than three times in three minutes. An attempt to dial a fourth time within three minutes will result in a "BLACKLISTED" result code. If the blacklist memory is full, any dial to a new number will result in a "BLACKLIST FULL" result code. Numbers are added to the blacklist only if the modem connection fails. The %B command will list the numbers on the blacklists.

0 – disabled
 1 – enabled

Range: 0, 1

Default: 0

Units: None

4.1.18 S43 Dial attempts to Blacklist

When blacklisting is enabled with S43, this value controls the number of dial attempts that will result in a number being blacklisted.

Range: 0—4

Units: None

4.1.19 S44 Blacklist Timer

This register sets the period during which blacklisting is active

Range: 0—255

Units: None

4.1.20 S50 Minimum On-hook Time

This register sets number of seconds the modem will remain on-hook. Any attempt to go off-hook will be delayed until this timer expires.

Range: 0—255

Default: 3

Units: seconds

4.1.21 S51 Outside Number

This register sets the number to start checking for an outside line on a PBX.

Range: 0—9

Default: 1

Filename	oem-modem-xxc2.doc	Document Revision	1.0
Date of Issue	18/02/2005	Page Number	41 of 61

5 User-Access Registers (U-Registers)

The OEM-MODEM-56C2/34C2/32C2/24C2 contains a number of user access registers (U-registers), which are used to configure the operation of modem. The :U AT command is used to write these 16-bit U-registers, and the :R command is used to read them. U registers are identified by a hexadecimal (hex) address.

Register	Address (Hex)	Name	Description	Default
U00	0x0000	DT1A0	DT1 registers set the coefficients for stage 1 of the Dial Tone Detect filter. Biquad coefficients can be programmed as 16-bit 2's compliment values scaled as 1.0 = 0xC000 with the formula: $H(z) = \frac{A0 + A1z^{-1} + A2z^{-2}}{1 + B1z^{-1} + B2z^{-2}}$	0x0800
U01	0x0001	DT1B1		0x0000
U02	0x0002	DT1B2		0x0000
U03	0x0003	DT1A2		0x0000
U04	0x0004	DT1A1		Default is for FCC countries. See Appendix B for other country settings.
U05	0x0005	DT2A0	Dial tone detect filters stage 2 biquad coefficients.	0x00A0
U06	0x0006	DT2B1		0x6EF1
U07	0x0007	DT2B2		0xC4F4
U08	0x0008	DT2A2		0xC000
U09	0x0009	DT2A1		0x0000
U0A	0x000A	DT3A0	Dial tone detect filters stage 3 biquad coefficients.	0x00A0
U0B	0x000B	DT3B1		0x78B0
U0C	0x000C	DT3B2		0xC305
U0D	0x000D	DT3A2		0x4000
U0E	0x000E	DT3A1		0xB50A
U0F	0x000F	DT4A0	Dial tone detect filters stage 4 biquad coefficients.	0x0400
U10	0x0010	DT4B1		0x70D2
U11	0x0011	DT4B2		0xC830
U12	0x0012	DT4A2		0x4000
U13	0x0013	DT4A1		0x80E2
U14	0x0014	DTK	Dial tone detect filter output scalar.	0x0009
U15	0x0015	DTON	Dial tone detect ON threshold.	0x00A0
U16	0x0016	DTOF	Dial tone detect OFF threshold.	0x0070
U17	0x0017	BT1A0	BT1 registers set the coefficients for stage 1 of the Busy Tone Detect filter. Default is for FCC countries. See Appendix B for other Country settings.	0x0800
U18	0x0018	BT1B1		0x0000
U19	0x0019	BT1B2		0x0000
U1A	0x001A	BT1A2		0x0000
U1B	0x001B	BT1A1		0x0000
U1C	0x001C	BT2A0	Busy tone detect filter stage 2 biquad coefficients.	0x00A0
U1D	0x001D	BT2B1		0x6EF1
U1E	0x001E	BT2B2		0xC4F4
U1F	0x001F	BT2A2		0xC000
U20	0x0020	BT2A1		0x0000
U21	0x0021	BT3A0	Busy tone detect filter stage 3 biquad coefficients.	0x00A0
U22	0x0022	BT3B1		0x78B0
U23	0x0023	BT3B2		0xC305
U24	0x0024	BT3A2		0x4000
U25	0x0025	BT3A1		0xB50A

Table 5.0: User-Access Registers Summary

Filename	oem-modem-xxc2.doc	Document Revision	1.0
Date of Issue	18/02/2005	Page Number	42 of 61

U26	0x0026	BT4A0	Busy tone detect filter stage 4 biquad coefficients.	0x0400
U27	0x0027	BT4B1		0x70D2
U28	0x0028	BT4B2		0xC830
U29	0x0029	BT4A2		0x4000
U2A	0x002A	BT4A1		0x80E2
U2B	0x002B	BTK	Busy tone detect filter output scalar.	0x0009
U2C	0x002C	BTON	Busy tone detect ON threshold.	0x00A0
U2D	0x002D	BTOF	Busy tone detect OFF threshold.	0x0070
U2E	0x002E	BMTT	<p>Busy cadence minimum total time in seconds multiplied by 7200. Country-specific settings for busy, ringback, and dialtone cadences are specified by a range for ON time (minimum ON and maximum ON) and a range for OFF time (minimum OFF and maximum OFF). The OEM-MODEM-XXC uses three registers to fully specify this range—MTT, DLT, and MOT. MTT is the minimum total time and is equal to the minimum ON time plus the minimum OFF time. DLT is the allowable delta. This is equal to maximum total time (maximum ON time plus the maximum OFF time) minus the minimum total time (MTT). MOT is simply the minimum ON time.</p> <p>Example: A country specifies a busy tone with on time from 1–2 seconds and off time from 3–4 seconds. Thus, minimum ON time = 1 sec, maximum ON time = 2 sec, minimum OFF time = 3 sec, and maximum OFF time = 4 sec. BMTT = 1 + 3 = 4 seconds, maximum total time = 2 + 4 = 6 seconds, so BDLT = 6 – 4 = 2 seconds, and BMOT = 1.</p>	0x0870
U2F	0x002F	BDLT	Busy cadence delta in seconds multiplied by 7200.	0x25F8
U30	0x0030	BMOT	Busy cadence minimum on time in seconds multiplied by 7200.	0x0438
U31	0x0031	RMTT	Ringback cadence minimum total time in seconds multiplied by 7200.	0x4650
U32	0x0032	RDLT	Ringback cadence delta in seconds multiplied by 7200.	0xEF10
U33	0x0033	RMOT	Ringback cadence minimum on time in seconds multiplied by 7200.	0x1200
U34	0x0034	DTWD	Window to look for dialtone in seconds multiplied by 1000.	0x1B58
U35	0x0035	DMOT	Minimum dialtone on time in seconds multiplied by 7200.	0x2D00
U37	0x0037	PD0	Number of pulses to dial 0.	0x000A
U38	0x0038	PD1	Number of pulses to dial 1.	0x0001
U39	0x0039	PD2	Number of pulses to dial 2.	0x0002
U3A	0x003A	PD3	Number of pulses to dial 3.	0x0003
U3B	0x003B	PD4	Number of pulses to dial 4.	0x0004
U3C	0x003C	PD5	Number of pulses to dial 5.	0x0005
U3D	0x003D	PD6	Number of pulses to dial 6.	0x0006
U3E	0x003E	PD7	Number of pulses to dial 7.	0x0007
U3F	0x003F	PD8	Number of pulses to dial 8.	0x0008
U40	0x0040	PD9	Number of pulses to dial 9.	0x0009

Table 5.0: User-Access Registers Summary (continued)

Filename	oem-modem-xxc2.doc	Document Revision	1.0
Date of Issue	18/02/2005	Page Number	43 of 61

U42	0x0042	PDBT	Pulse dial break time (msec units).	0x003D
U43	0x0043	PDMT	Pulse dial make time (msec units).	0x0027
U45	0x0045	PDIT	Pulse dial interdigit time (msec units).	0x0320
U46	0x0046	DTPL	DTMF power level—16-bit format is 0x0(H)(L)0. Where H is the (-)dBm level of the high-frequency DTMF tone and L is the (-)dBm level of the low-frequency DTMF tone. Note that twist may be specified here.	0x09B0
U47	0x0047	DTNT	DTMF on time (msec units).	0x0064
U48	0x0048	DTFT	DTMF off time (msec units).	0x0064
U49	0x0049	RGFH	Ring frequency high—Maximum frequency ring to be considered a valid ring. RGFH = 2400/(maximum ring frequency).	0x0022
U4A	0x004A	RGFD	Ring delta RGFD = $2400\text{Hz} \times \frac{1}{\text{min ring freq (Hz)}} - \frac{1}{\text{max ring freq (Hz)}}$	0x007A
U4B	0x004B	RGMN	Ring cadence minimum ON time in seconds multiplied by 2400.	0x0258
U4C	0x004C	RGNX	Ring cadence maximum total cadence in seconds multiplied by 2400.	0x6720
U4D	0x004D	MOD1	This is a bit-mapped register.	0x0000
U4E	0x004E	PRDD	Pre-dial delay-time after ATD command that modem waits to dial (msec units). The OEM-MODEM-XXC stays on-hook during this time.	0x0000
U4F	0x004F	FHT	Flash Hook Time. Time corresponding with “!” or “&” dial modifier that the OEM-MODEM-XXC goes on-hook during a flash hook (msec units).	0x01F4
U50	0x0050	LCDN	Loop current debounce on time (msec units).	0x015E
U51	0x0051	LCDF	Loop current debounce off time (msec units).	0x00C8
U52	0x0052	XMTL	Transmit level (1 dB units)—Sets the modem data pump transmitter level. Default level of 0 corresponds to -9.85 dBm. Transmit level = -(9.85 + XMTL) dBm. Range = -9.85 to -48.	0x0000
U53	0x0053	MOD2	This is a bit-mapped register.	0x0000
U62	0x0062	DAAC1	This is a bit-mapped register.	0x0804
U65	0x0065	DAAC4	This is a bit-mapped register.	0x00E0
U66	0x0066	DAAC5	This is a bit-mapped register.	0x0040
U67	0x0067	ITC1	This is a bit-mapped register.	0x0008
U68	0x0068	ITC2	This is a bit-mapped register.	0x0000
U69	0x0069	ITC3	This is a bit-mapped register.	0x0006
U6A	0x006A	ITC4	This is a bit-mapped register.	n/a
U6C	0x006C	V29E	V29 EPOS handshake enable.	0x0000
U6E	0x006E	CK1	This is a bit-mapped register.	0x1F20
U6F	0x006F	PTMR	This is a bit-mapped register.	0x00FF
U70	0x0070	IO0	This is a bit-mapped register.	0x2700
U76	0x0076	GEN1	This is a bit-mapped register.	0x3240
U77	0x0077	GEN2	This is a bit-mapped register.	0x401E
U78	0x0078	GEN3	This is a bit-mapped register.	0x0000
U79	0x0079	GEN4	This is a bit-mapped register.	0x0000
U7A	0x007A	GENA	This is a bit-mapped register.	0x0000
U7C	0x007C	GENC	This is a bit-mapped register.	0x0000
U7D	0x007D	GEND	This is a bit-mapped register.	0x0000

Table 5.0: User-Access Registers Summary (continued)

Filename	oem-modem-xxc2.doc	Document Revision	1.0
Date of Issue	18/02/2005	Page Number	44 of 61

U83	0x0083	NOLN	No-Line threshold. If %V1 is set, NOLN sets the threshold for determination of line present vs. line not present.	0x0001
U84	0x0084	LIUS	Line-in-use threshold. If %V1 is set, LIUS sets the threshold for determination of line in use vs. line not in use.	0x0007
U85	0x0085	NLIU	Line-in-use/No line threshold. If %V2 is set, NLIU sets the threshold reference for the adaptive algorithm (see %V2).	0x0000
U86	0x0086	V9AGG	V.90 rate reduction in 1333 bps units.	0x0000

Table 5.0: User-Access Registers Summary (continued)

Reg.	Name	Bit 15	Bit 14	Bit 13	Bit 12	Bit 11	Bit 10	Bit 9	Bit 8	Bit 7	Bit 6	Bit 5	Bit 4	Bit 3	Bit 2	Bit 1	Bit 0
U4D	MOD1		TOCT		NHFP	NHFD	CLPD		FTP	SPDM		GT18	GT66	CTE		LLC	LCN
U53	MOD2	REV															
U62	DAAC1													FOH	DL		
U65	DAAC4	PWM	PWVG	PDN									PDL				
U66	DAAC5									FDT							
U67	ITC1								OFF	OHS	ACT			DCT[1:0]	RZ	RT	
U68	ITC2												LIM	BTE	ROV	BTD	
U69	ITC3									DIAL	FJM	VOL	FLVM	MODE			
U6A	ITC4													OVL			
U6E	CK1																
U6F	PTME																
U70	IO0	HES		TES	CIDM	OCDM	PPDM	RIM	DCDM				CID	OCD	PPD	RI	DCD
U76	GEN1								FACL				DCL[2:0]				ACL[4:0]
U77	GEN2																OHT[8:0]
U78	GEN3		IB[1:0]														IS[7:0]
U79	GEN4																LVCS[4:0]
U7A	GENA									DOP	ADD					HDLC	FAST
U7C	GENC												RIGPO				RIG-POEN
U7D	GEND						LLV	AUSDC								ATZD	FDP

Table 5.1: Bit-Mapped U-Register Summary

Filename	oem-modem-xxc2.doc	Document Revision	1.0
Date of Issue	18/02/2005	Page Number	45 of 61

5.1 User-Access Bitmapped Reference

U4D MOD1

Reset settings = 0x0000

Bit	Type	Name	Function
15		Reserved	Read returns zero.
14	R/W	TOCT	Turn Off Calling Tone. 0 = Disable. 1 = Enable.
13		Reserved	Read returns zero.
12	R/W	NHFP	No Hook Flash Pulse. 0 = Disable. 1 = Enable.
11	R/W	NHFD	No Hook Flash Dial. 0 = Disable. 1 = Enable.
10	R/W	CLPD	Check Loop Current Before Dialling. 0 = Ignore. 1 = Check.
9	R/W	CCAD	Check Carrier at Data (confirm carrier before entering Data mode). 0 = Disable. 1 = Enable.
8	R/W	FTP	Force Tone or Pulse. 0 = Disable. 1 = Enable.
7	R/W	SPDM	Skip Pulse Dial Modifier. 0 = No. 1 = Yes.
6		Reserved	Read returns zero.
5	R/W	GT18	1800 Hz Guard Tone Enable. 0 = Disable. 1 = Enable.
4	R/W	GT55	550 Hz Guard Tone Enable. 0 = Disable 1 = Enable.
3	R/W	CTE	Calling Tone Enable. 0 = Disable. 1 = Enable.
2		Reserved	Read returns zero.
1	R/W	LLC	Low Loop Current Detect (required for CTR21). 0 = Disabled. 1 = Enabled.
0	R/W	LCN	Loop Current Needed. 0 = No. 1 = Yes.

Filename	oem-modem-xxc2.doc	Document Revision	1.0
Date of Issue	18/02/2005	Page Number	46 of 61

U53 MOD2

Reset settings = 0x0000

Bit	Type	Name	Function
15	R/W	REV	V.23 Reversing. 0 = Disable. 1 = Enable.
14:0		Reserved	Reads zero.

U62 DAAC1

Reset settings = 0x0804

Bit	Type	Name	Function
15:12		Reserved	Must be set to zero.
11		Reserved	Must be set to one
10:3		Reserved	Must be set to zero.
2	R/W	FOH	Fast Off-Hook. 0 = Automatic Calibration Time set to 426 ms 1 = Automatic Calibration Time set to 106 ms
1	R/W	DL	Isolation Digital Loopback (see the AT&T commands). 0 = Loopback occurs beyond the ISOcap interface, out to and including the analogue hybrid circuit. 1 = Enables digital loopback mode across isolation barrier only.
0		Reserved	Must be set to zero.

U65 DACC4

Reset settings = 0x00E0

Bit	Type	Name	Function
15	R/W	PWM	PWM Mode. 0 = Normal. Classic PWM output waveform. 1 = Scrambled mode.
14	R/W	PWMG	PWM Gain. 0 = No gain. 1 = 6 dB gain applied to AOUT.
13	R/W	PDN	Power Down. Completely powerdown the OEM-MODEM-xxC2. Once set to 1, the OEM-MODEM-xxC2 must be reset in order to power on. 0 = Normal. 1 = Power down.
12:8		Reserved	Read returns zero
7:5		Reserved	Must not change in a read-modify-write.
4	R/W	PDL	Power Down Line-Side Chip. 0 = Normal operation. 1 = Places the Si3015 in powerdown mode. Note: Typically used only for board-level debug.
3:0		Reserved	Must not change in a read-modify-write.

Filename	oem-modem-xxc2.doc	Document Revision	1.0
Date of Issue	18/02/2005	Page Number	47 of 61

U66 DACC5

Reset settings = 0x0000

Bit	Type	Name	Function
15:7		Reserved	Read returns zero.
6	R	FDT	Frame Detect. 0 = Indicates ISOcap has not established frame lock. 1 = Indicates ISOcap frame lock has been established. Note: Typically used only for board-level debug.
5:4		Reserved	Read returns zero.
3:0		Reserved	Do not modify.

U67 ITC1

Reset settings = 0x0008

Bit	Type	Name	Function
15:8		Reserved	Read returns zero.
7	R/W	OFF	DC Termination Off. 0 = Normal operation. The OFF bit must always be set to 0 when on-hook. 1 = DC termination disabled and the device presents an 800. dc impedance to the line which is used to enhance operation with an off-hook parallel phone.
6	R/W	OHS	On Hook Speed 0 = The modem will execute a fast on-hook. 1 = The modem will execute a slow, controlled on-hook.
5	R/W	ACT	AC Termination Select. 0 = Selects the real impedance. 1 = Selects the complex impedance.
4		Reserved	Read returns zero.
3:2	R/W	DCT	DC Termination Select. 00 = Low Voltage mode (Transmit level = -13.85 dBm). 01 = Japan mode (Transmit level = -11.85 dBm). 10 = FCC mode. Standard voltage mode (Tx level = -9.85 dBm). 11 = CTR21 mode. Current limiting mode (Tx level = -9.85 dBm).
1	R/W	RZ	Ringer Impedance. 0 = Maximum (high) ringer impedance. 1 = Synthesise ringer impedance.
0	R/W	RT	Ringer Threshold Select. Used to satisfy country requirements on ring detection. Signals below the lower level will not generate a ring detection; signals above the upper level are guaranteed to generate a ring detection. 0 = 11 to 22 VRMS. 1 = 17 to 33 VRMS.

Filename	oem-modem-xxc2.doc	Document Revision	1.0
Date of Issue	18/02/2005	Page Number	48 of 61

U68 ITC2

Reset settings = 0x0000

Bit	Type	Name	Function
15:8		Reserved	Read returns zero.
7:5		Reserved	Do not modify.
4	R/W	LIM	Current Limit. 0 = All other modes. 1 = CTR21 mode.
3		Reserved	Do not modify.
2	R/W	BTE	Billing Tone Protect Enable. 0 = Disabled. 1 = Enabled. When set, the DAA will automatically respond to a collapse of the line-derived power supply during a billing tone event. When off-hook, if BTE = 1 and BTM goes high, the dc termination is released (800 . presented to line). If BTE and RIM (U70, bit 9) are set, then an RI (U70, bit 1) interrupt will also occur when BTM goes high.
1	R/W	ROV	Receive Overload. The bit is set when the receive input (i.e., receive pin goes below ground) has an excessive input level. This bit is cleared by writing a 0 to this location. 0 = Normal receive input level. 1 = Excessive receive input level.
0	R/W	BTM	Billing Tone Detected. This bit will be set if a billing tone is detected. This bit is cleared by writing a 0 to this location. 0 = No billing tone. 1 = Billing tone detected.

Filename	oem-modem-xxc2.doc	Document Revision	1.0
Date of Issue	18/02/2005	Page Number	49 of 61

U69 ITC3

Reset settings = 0x0000

Bit	Type	Name	Function
15:8		Reserved	Read returns zero.
7	R/W	FULL	Full Scale. 0 = Si3015 ADC/DAC full scale > -1 dBm. 1 = Si3015 ADC/DAC full scale > 3.2 dBm. This bit changes the full scale of the ADC and DAC from -1 dBm min to 3.2 dBm min. In order to use this bit, the R2 resistor must be changed from 402Ω to 243Ω and ACT (U67, bit 5) must be set to 0. This bit is intended for use only in voice communications and may be used in PCM modes.
6	R/W	DIAL	DTMF Dialling Mode. This bit should be set during DTMF dialling in CTR21 mode if LVCS < 12. 0 = Normal operation. 1 = Increase headroom for DTMF dialling.
5	R/W	FJM	Force Japan DC Termination Mode. 0 = Normal Gain. 1 = When DCT = 2 (FCC mode), setting this bit will force Japan dc termination mode while allowing for a transmit level of -1 dBm.
4	R/W	VOL	Line Voltage Adjust. When set, this bit will adjust the TIP-RING line voltage. Lowering this voltage will improve margin in low voltage countries. Raising this voltage may improve large signal distortion performance. 0 = Normal operation. 1 = Lower DCT voltage.
3	R/W	FLVM	Force Low Voltage Mode. When DCT (U67, bits 3:2) = 10 (FCC mode), setting FLVM will force the Low Voltage mode (see DCT = 00) while allowing for a transmit level of -1 dBm. 0 = Disable. 1 = Enable.
2	R/W	MODE	MODE MODE = 1b enables on-hook line monitor. MODE must be disabled (MODE = 0b) before the Modem can go off-hook, dial, or answer a call. 0 = Disable. 1 = Enable.
1:0		Reserved	Do not modify.

Filename	oem-modem-xxc2.doc	Document Revision	1.0
Date of Issue	18/02/2005	Page Number	50 of 61

U6A ITC4

Reset settings = N/A

Bit	Type	Name	Function
15:3		Reserved	Read returns zero.
2	R	OVL	Overload Detected. This bit has the same function as ROV, but will clear itself after the overload has been removed. See "Billing Tone Detection" on page 72. This bit is not affected by the BTE bit.
1:0		Reserved	Do not modify.

U6E CK1

Reset settings = 0x1F00

Bit	Type	Name	Function
15:13		Reserved	Do not modify
12:8	R/W	R1	R1 CLKOUT Divider 0 CLKOUT off. R1 R1 + 1 (default R1 = 31; 2.4576 MHz). R1 = 31 required for proper codec interface operation.
7:0		Reserved	Read returns zero

Filename	oem-modem-xxc2.doc	Document Revision	1.0
Date of Issue	18/02/2005	Page Number	51 of 61

U70 IO0

Reset settings = 0x2F00

Bit	Type	Name	Function
15	R/W	HES	Hardware Escape Pin. 0 = Disable. 1 = Enable.
14		Reserved	Read returns zero.
13	R/W	TES	Enable “+++” Escape. 0 = Disable. 1 = Enable.
12	R/W	CIDM	Caller ID Mask. 0 = Change in CID will not affect INT. 1 = A low to high transition in CID will activate INT.
11	R/W	OCDM	Overcurrent Detect Mask. 0 = Change in OCD will not affect INT. (“X” result code will not be generated in command mode.) 1 = A low to high transition in OCD will activate INT. (“X” result code is generated in command mode.)
10	R/W	PPDM	Parallel Phone Detect Mask. 0 = Change in PPD will not affect INT. 1 = A low to high transition in PPD will activate INT.
9	R/W	RIM	Ring Indicator Mask. 0 = Change in RI will not affect INT. 1 = A low to high transition in RI will activate INT.
8	R/W	DCDM	Data Carrier Detect Mask. 0 = Change in DCD will not affect INT. 1 = A high to low transition in DCD (U70, bit 0), which indicates loss of carrier, will activate INT.
7	R/W	RSTM	Reset Mask. 0 = Software reset will not affect INT. 1 = Software reset will activate INT.
6		Reserved	Read returns zero.
5	R/W	RST	Reset (sticky). The modem has begun a software reset. Clears on :I read.
4	R/W	CID	Caller ID (sticky). Caller ID preamble has been detected; data will soon follow. Clears on :I read.
3	R/W	OCD	Overcurrent Detect (sticky). Overcurrent condition has occurred. Clears on :I read.
2	R/W	PPD	Parallel Phone Detect (sticky). Parallel phone detected since last off-hook event. Clears on :I read.
1	R/W	RI	Ring Indicator (sticky). Active high bit indicates ring event has occurred. Clears on :I read.
0	R/W	DCD	Data Carrier Detect (status). Active high bit indicates carrier detected (equivalent to inverse of DCD pin).

Filename	oem-modem-xxc2.doc	Document Revision	1.0
Date of Issue	18/02/2005	Page Number	52 of 61

U76 GEN1

Reset settings = 0x3240

Bit	Type	Name	Function
15:9	R/W	OHSR	Off-Hook Sample Rate (40 ms units) Sets the sample rate for the off-hook intrusion algorithms (1 second default).
8	R/W	FACL	Force ACL. 0 = While off-hook, ACL is automatically updated with LVCS. 1 = While off-hook, ACL does not change from the value written to it while on-hook.
7:5	R/W	DCL	Differential Current Level (3 mA units). Sets the differential level between ACL and LVCS that will trigger an off-hook PPD interrupt (default = 2).
4:0	R/W	ACL	Absolute Current Level (3 mA units). ACL represents the value of LVCS current when the modem is off-hook and all parallel phones are on-hook. If ACL = 0, then it is ignored by the off-hook intrusion algorithm. The modem will also write ACL with the contents of LVCS before an intrusion and before going on-hook (default = 0).

U77 GEN2

Reset settings = 0x4610

Bit	Type	Name	Function
15:12	R/W	IST	Intrusion Settling Time (250 ms units). Delay between when the modem goes off-hook and the off-hook intrusion algorithm begins. Default is 1 second.
11	R/W	HOI	Hang-Up On Intrusion. 0 = modem will not automatically hang up when an off-hook PPD interrupt occurs. 1 = modem automatically hangs up on a PPD interrupt.
9	R/W	AOC	Overcurrent Protection. Enable Overcurrent protection. 0 = Disable. 1 = Enable.
8:0	R/W	OHT	Off-Hook Time (1 ms units). Time before LVCS is checked for overcurrent condition after going off-hook (16 ms default).

Filename	oem-modem-xxc2.doc	Document Revision	1.0
Date of Issue	18/02/2005	Page Number	53 of 61

U78 GEN3

Reset settings = 0x0000

Bit	Type	Name	Function
15:14	R/W	IB	Intrusion Blocking Defines the method used to block the off-hook intrusion algorithm from operation after dialling has begun. 0 = No intrusion blocking. 1 = Intrusion disabled from start of dial to end of dial. 2 = Intrusion disabled from start of dial to IS register time-out. 3 = Intrusion disabled from start of dial to connect ("CONNECT xxx", "NO DIALTONE", or "NO CARRIER").
13:8		Reserved	Read returns to zero.
7:0	R/W	IS	Intrusion Suspend (500 ms units). When IB = 2, this register sets the length of time from when dialling begins that the off-hook intrusion algorithm is blocked (suspended) (default = 00000000b).

U79 GEN4

Reset settings = 0x0000

Bit	Type	Name	Function
15:5		Reserved	Read returns zero.
4:0	R/W	LVCS	Line Voltage Current Sense. Represents either the line voltage, loop current, or on-hook line monitor depending on the state of the MODE, OFHK, and ONHM bits. On-Hook Voltage Monitor (2.75 V/bit ±20%) (refer to section 2.6.1). 00000 = No line connected. 00001 = Minimum line voltage ($V_{MIN} = 3.0\text{ V} \pm 0.5\text{ V}$). 11111 = Maximum line voltage ($87\text{ V} \pm 20\%$). The line voltage monitor full scale may be modified by changing R5 as follows: $V_{MAX} = V_{MIN} + 4.2 (10M + R5 + 1.6k)/(R5 + 1.6k)/5$ U69[2] (MODE) must be set to 1b before reading LVCS while the modem is on-hook. See MODE on page. U69[2] (MODE) must be disabled (MODE = 0b) before the modem can go off-hook, dial, or answer a call. Off-Hook Loop Current Monitor (3 mA/bit) refer to section 2.6.2). 00000 = No loop current. 00001 = Minimum loop current. 11110 = Maximum loop current. 11111 = Loop current is excessive (overload). Overload > 140 mA in all modes

Filename	oem-modem-xxc2.doc	Document Revision	1.0
Date of Issue	18/02/2005	Page Number	54 of 61

U7A GENA

Reset settings = 0x0000

Bit	Type	Name	Function
15:8		Reserved	Read returns zero.
7	R/W	DOP	Dial or Pulse. 0 = Normal ATDTW operation 1 = Use ATDTW for Pulse/Tone Dial Detection (see also ATDW command)
6	R/W	ADD	Adaptive Dialing 1 = Enable 0 = Disable Attempt DTMF dial, then fall back to pulse dialing if unsuccessful. First digit is dialed as DTMF. If a dialtone is still present after two seconds, the OEM-MODEM-xxC2 will redial the first digit and remaining digits as pulse. If a dialtone is not present after two seconds, the modem will dial the remaining digits as DTMF
5:2		Reserved	Read returns zero.
1	R/W	HDLC	Synchronous Mode.* 0 = Normal asynchronous mode. 1 = Transparent HDLC mode.
0	R/W	FAST	Fast Connect.* 0 = Normal modem handshake timing per ITU/Bellcore standards. 1 = Fast connect modem handshake timing.
*Note: When V22HD, HDLC, or FAST bits are set, \N0 (wire mode) must be used.			

U7C GENC

Reset settings = 0x0000

Bit	Type	Name	Function
15:5		Reserved	Read returns zero.
4	R	RIGPO	RI. RI (pin 9), follows this bit when RIGPIOEN = 1b.
3:1		Reserved	Read returns zero.
0	R/W	RIGPOEN	0 = RI indicates valid ring signal (Normal ring-indicator mode). 1 = RI (Pin 9) can be used as a general-purpose output and follows U7C[4] (RIGPO).

Filename	oem-modem-xxc2.doc	Document Revision	1.0
Date of Issue	18/02/2005	Page Number	55 of 61

U7D GEND

Reset settings = 0x0000

Bit	Type	Name	Function
15:11		Reserved	Read returns zero.
10	R/W	LLV	0 = Normal operation. 1 = Enables an optional algorithm for countries, such as Japan and Malaysia, with low loop voltage. Also set U67[3:2] (DCT) = 00b, U69[4] VOL = 1b, and U52 = 0x0002 before going off-hook. When the modem goes off-hook, it samples LVCS and changes DCT and VOL as necessary to maximize transmit levels and optimize distortion.
9	R/W	AUSDC	0 = Normal operation. 1 = Causes the modem to go off-hook in Japan mode and then revert to FCC mode after 500 ms. This allows the modem to meet the Australian line seizure requirements while allowing the maximum transmit power (optional for Australia and when DCT = 01b).
8:2		Reserved	Read returns zero.
1	R/W	ATZD	ATZ Disable. 0 = ATZ functions normally. 1 = Disable ATZ command. This may be used to ensure modem settings are not lost in some systems.
0	R/W	FDP	FSK Data Processing. 0 = FSK data processing stops when carrier is lost. 1 = FSK data processing continued for 2 bytes after carrier is lost.

Filename	oem-modem-xxc2.doc	Document Revision	1.0
Date of Issue	18/02/2005	Page Number	56 of 61

6 CONNECTOR SPECIFICATIONS

6.1 SERIAL HOST INTERFACE

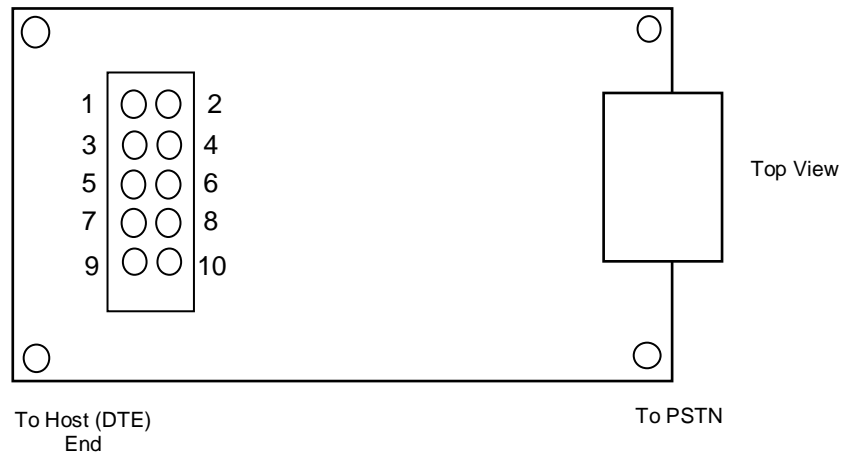

6.2 HOST INTERFACE DESCRIPTION

PIN	NAME	Direction	DESCRIPTION
1	+5v	-	External Power Supply
2	GnD	-	External Ground
3	RxD	output	Receive Data
4	TxD	Input	Transmit Data
5	/DTR	Input	Data Terminal Ready
6	/DCD	output	Data Carrier Detect
7	/RTS	Input	Request To Send
8	/CTS	output	Clear to Send
9	/RI	output	Ring Indicator
10	/RESET	Input	Reset

Filename	oem-modem-xxc2.doc	Document Revision	1.0
Date of Issue	18/02/2005	Page Number	57 of 61

6.3 TELEPHONE CONNECTION

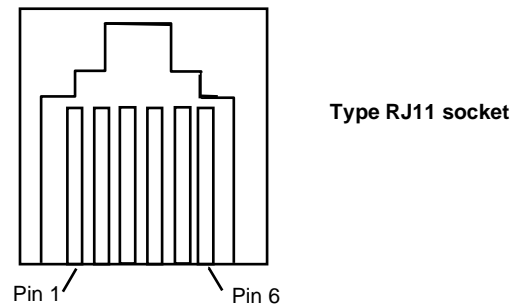

RJ11 Connections are as follows:-

Pin 1	Not used	Pin 4	Line
Pin 2	Not used	Pin 5	Not used
Pin 3	Line	Pin 6	Not used

The plug terminating the other end of the telephone lead is a type 431A. The pin configuration in this plug is the same as the RJ11 connection.

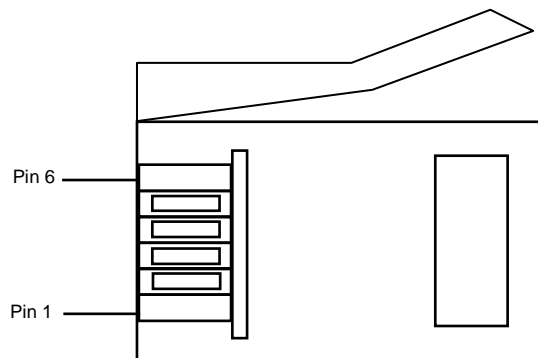

Type 431A Plug

Type 431A Plug Connections are as follows:

Pin 1	Not used	Not used
Pin 2	White	Line
Pin 3	Green	Not used
Pin 4	Blue	Not used
Pin 5	Red	Line
Pin 6	Not used	Not used

Filename	oem-modem-xxc2.doc	Document Revision	1.0
Date of Issue	18/02/2005	Page Number	58 of 61

7 ELECTRICAL CHARACTERISTICS

7.1 DC Electrical Characteristics

TA = 0 to 70 degrees Centigrade

	Min	Typ	Max	Units
Vcc	TBA	TBA	TBA	Volts
Icc	TBA	TBA	TBA	mA
Icc1 (data mode)	TBA	TBA	TBA	mA
Icc2 (Reset)	TBA	TBA	TBA	mA
Vil	TBA	TBA	TBA	V
Vih	TBA	TBA	TBA	V
Voh	TBA	TBA	TBA	Volts
Vol	TBA	TBA	TBA	Volts
Iil input leakage	TBA	TBA	TBA	UA
Iol output leakage	TBA	TBA	TBA	UA

7.2 Timing Characteristics

	Min	Max	Units
t1. Rise and Fall Times	TBA	TBA	nS
t2. Reset low Time	TBA	TBA	mS
t3. Reset Recovery to Data	TBA	TBA	mS

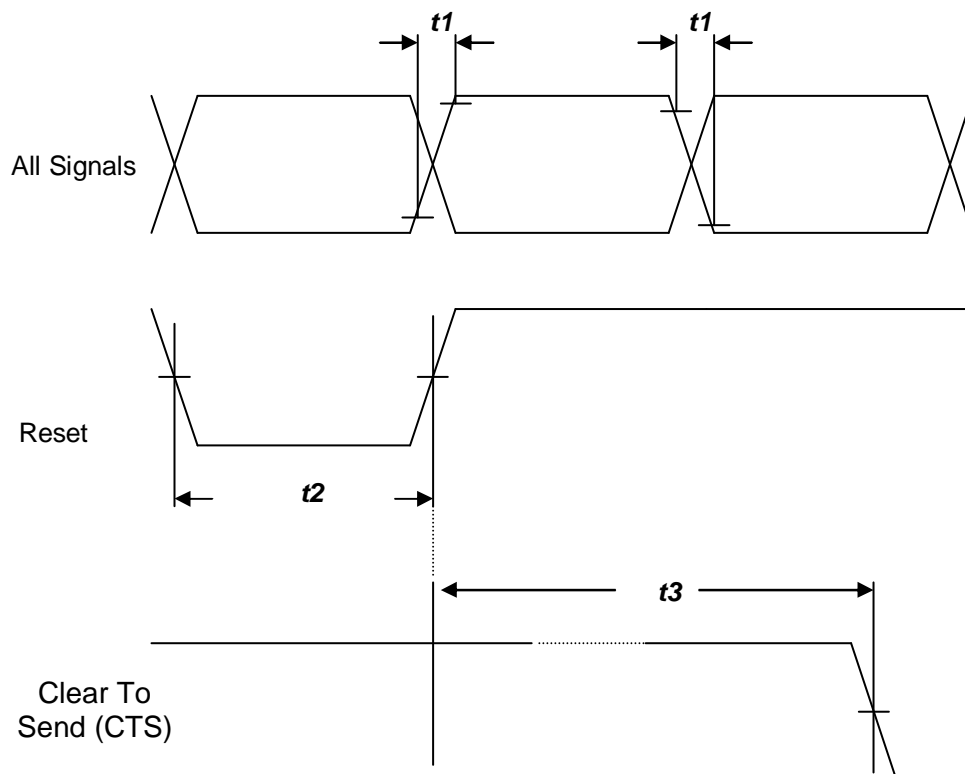

Filename	oem-modem-xxc2.doc	Document Revision	1.0
Date of Issue	18/02/2005	Page Number	59 of 61

8 MECHANICAL SPECIFICATIONS

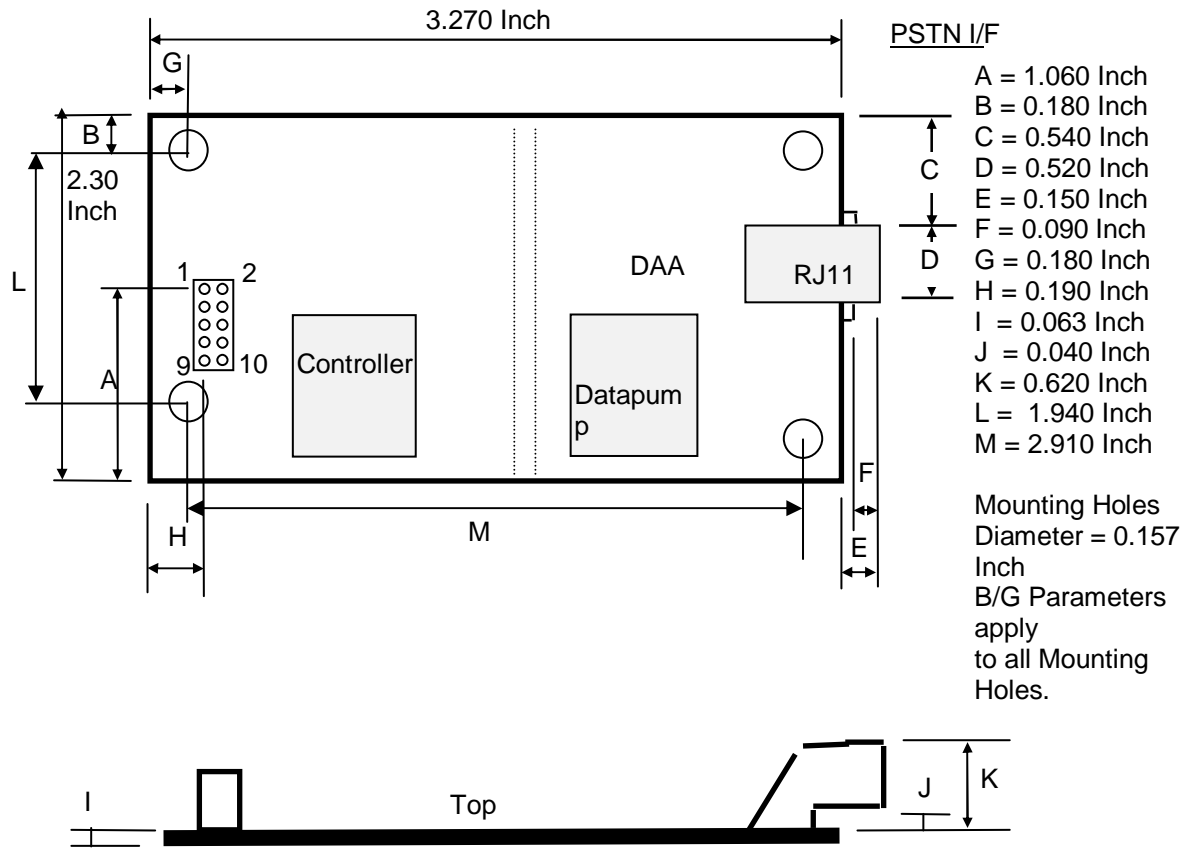

1. RJ11 socket is not flush with the PCB, allowing space for the Host enclosure.
2. All dimensions are +/- .020 inch.

Filename	oem-modem-xxc2.doc	Document Revision	1.0
Date of Issue	18/02/2005	Page Number	60 of 61

